

Property Record Card



Parcel 27-21-30-513-0000-3460

Property Address 1301 BLUE STEM LN WINTER PARK, FL 32792

Parcel Location

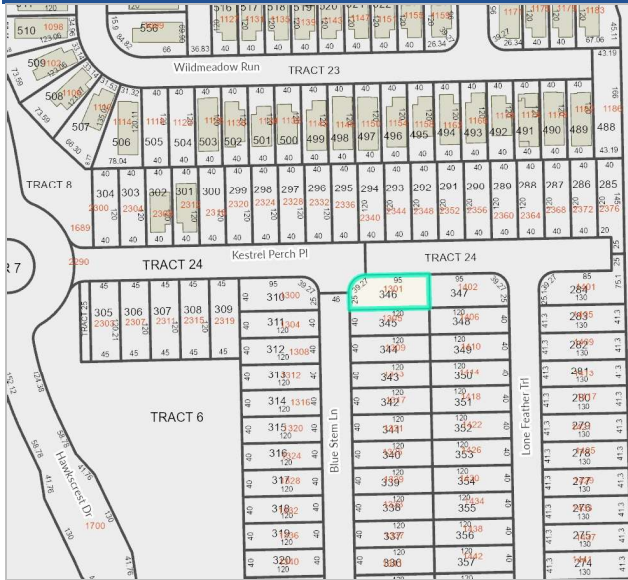

Site View



Parcel Information

Parcel	27-21-30-513-0000-3460
Owner(s)	BAUMGARTNER, ALEXANDER J - Tenancy by Entirety BAUMGARTNER, BRITTANY - Tenancy by Entirety
Property Address	1301 BLUE STEM LN WINTER PARK, FL 32792
Mailing	1301 BLUE STEM LN WINTER PARK, FL 32792-3038
Subdivision Name	LANDINGS AT HAWKS CREST
Tax District	01-COUNTY-TX DIST 1
DOR Use Code	01-SINGLE FAMILY
Exemptions	None
AG Classification	No

Value Summary

	2023 Working Values	2022 Certified Values
Valuation Method	Cost/Market	Cost/Market
Number of Buildings	1	0
Depreciated Bldg Value	\$375,186	
Depreciated EXFT Value		
Land Value (Market)	\$120,000	\$105,000
Land Value Ag		
Just/Market Value	\$495,186	\$105,000
Portability Adj		
Save Our Homes Adj	\$0	\$0
Amendment 1 Adj	\$0	\$6,000
P&G Adj	\$0	\$0
Assessed Value	\$495,186	\$99,000

2022 Certified Tax Summary

2022 Tax Amount without Exemptions	\$1,407.85	2022 Tax Savings with Exemptions	\$47.69
2022 Tax Bill Amount	\$1,360.16		

* Does NOT INCLUDE Non Ad Valorem Assessments

Legal Description

LOT 346 LANDINGS AT HAWKS CREST PLAT BOOK 85 PAGES 51-55

Taxes

Taxing Authority	Assessment Value	Exempt Values	Taxable Value
ROAD DISTRICT	\$495,186	\$0	\$495,186
SJWM(Saint Johns Water Management)	\$495,186	\$0	\$495,186
FIRE	\$495,186	\$0	\$495,186
COUNTY GENERAL FUND	\$495,186	\$0	\$495,186
Schools	\$495,186	\$0	\$495,186

Sales

Description	Date	Book	Page	Amount	Qualified	Vac/Imp
SPECIAL WARRANTY DEED	12/28/2022	10375	0106	\$625,600	Yes	Improved

Land

Method	Frontage	Depth	Units	Units Price	Land Value
LOT			1	\$120,000.00	\$120,000

Building Information

#	Description	Year Built**	Bed	Bath	Fixtures	Base Area	Total SF	Living SF	Ext Wall	Adj Value	Repl Value	Appendages										
1	SINGLE FAMILY	2022	4	2.5	11	992	3,128	2,416	CB/STUCCO FINISH	\$375,186	\$375,186	<table border="1" style="width: 100%; border-collapse: collapse;"> <thead> <tr style="background-color: #003366; color: white;"> <th>Description</th> <th>Area</th> </tr> </thead> <tbody> <tr> <td>OPEN PORCH FINISHED</td> <td style="text-align: right;">150.00</td> </tr> <tr> <td>OPEN PORCH FINISHED</td> <td style="text-align: right;">56.00</td> </tr> <tr> <td>GARAGE FINISHED</td> <td style="text-align: right;">506.00</td> </tr> <tr> <td>UPPER STORY FINISHED</td> <td style="text-align: right;">1424.00</td> </tr> </tbody> </table>	Description	Area	OPEN PORCH FINISHED	150.00	OPEN PORCH FINISHED	56.00	GARAGE FINISHED	506.00	UPPER STORY FINISHED	1424.00
Description	Area																					
OPEN PORCH FINISHED	150.00																					
OPEN PORCH FINISHED	56.00																					
GARAGE FINISHED	506.00																					
UPPER STORY FINISHED	1424.00																					

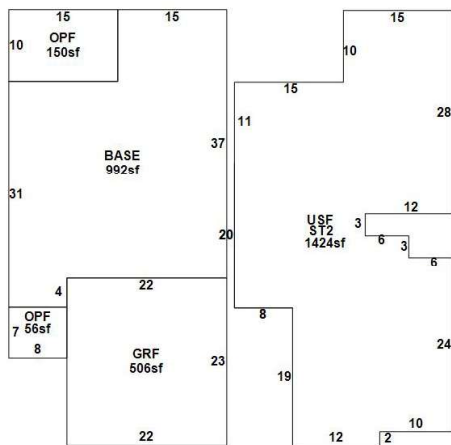

** Year Built (Actual / Effective)

Permits

Permit #	Description	Agency	Amount	CO Date	Permit Date
23051	1301 BLUE STEM LN: SINGLE FAMILY DETACHED-New SFR with Tug [LANDINGS AT HAWKS CREST]	County	\$353,220	12/16/2022	12/28/2021

Extra Features

Description	Year Built	Units	Value	New Cost
-------------	------------	-------	-------	----------

Zoning

Zoning	Zoning Description	Future Land Use	Future Land Use Description
PD	Planned Development	PD	Planned Development

Utility Information

Fire Station	Power	Phone(Analog)	Water Provider	Sewer Provider	Garbage Pickup	Recycle	Yard Waste	Hauler
23.00	DUKE	CENTURY LINK	SEMINOLE COUNTY UTILITIES	SEMINOLE COUNTY UTILITIES	NA	NA	NA	NA

Political Representation

Commissioner	US Congress	State House	State Senate	Voting Precinct
Dist 1 - Bob Dallari	Dist 7 - Cory Mills	Dist 30 - Susan Plasencia	Dist 9 - Jason Brodeur	65

School Information

Elementary School District	Middle School District	High School District
Eastbrook	Tuskawilla	Lake Howell

Copyright 2023 © Seminole County Property Appraiser