



SEMINOLE COUNTY
 PLANNING & DEVELOPMENT DIVISION
 1101 EAST FIRST STREET, ROOM 2028
 SANFORD, FLORIDA 32771
 (407) 665-7371 EPLANDESK@SEMINOLECOUNTYFL.GOV

PROJ. #: 24-80000139
 12 12 24

PRE-APPLICATION

INCOMPLETE APPLICATIONS WILL NOT BE ACCEPTED

APPLICATION FEE

<input checked="" type="checkbox"/> PRE-APPLICATION	\$50.00
---	---------

PROJECT

PROJECT NAME: Village on the Green Duplex Expansion	
PARCEL ID #(S): 03-21-29-300-009M-0000, 03-21-29-5WA-0000-0010	
TOTAL ACREAGE: 82 91	BCC DISTRICT: District 3
ZONING: Planned Development (PD)	FUTURE LAND USE: Planned Development (PD)

APPLICANT

NAME: Russell Mauk	COMPANY: Lifespace Communities Inc.	
ADDRESS: 3501 Olympus Blvd, Suite 300		
CITY: Dallas	STATE: TX	ZIP: 32801
PHONE: (512) 321-2495	EMAIL: Russell.Mauk@lifespacecommunities.com	

CONSULTANT

NAME: Brooks A. Stickler	COMPANY: Kimley-Horn and Associates, Inc.	
ADDRESS: 200 S. Orange Avenue, Suite 600		
CITY: Orlando	STATE: FL	ZIP: 32801
PHONE: (407) 427-1677	EMAIL: Brooks.Stickler@kimley-horn.com	

PROPOSED DEVELOPMENT (CHECK ALL THAT APPLY)

<input type="checkbox"/> SUBDIVISION	<input type="checkbox"/> LAND USE AMENDMENT	<input type="checkbox"/> REZONE	<input checked="" type="checkbox"/> SITE PLAN	<input type="checkbox"/> SPECIAL EXCEPTION
Description of proposed development: <u>Demolition of existing building on site. Proposed duplex development with supporting infrastructure and recreation facilities.</u>				

STAFF USE ONLY

COMMENTS DUE: 12/20	COM DOC DUE: 12/27	DRC MEETING: 1/8
<input type="checkbox"/> PROPERTY APPRAISER SHEET <input type="checkbox"/> PRIOR REVIEWS:		
ZONING: PD	FLU: PD	LOCATION: on the east side of Wekiva Springs Rd, north of W SR 434
W/S: Sunshine Water	BCC: 3: Constantine	

December 11, 2024

Seminole County Planning & Development Division
1101 East First Street
Sanford, FL 32771

Re: **Pre-Application Narrative**
Village on the Green Duplex Expansion
Master Development Plan for Village on the Green and Sabal Point

Seminole County Planning and Development,

Please accept this formal request for a Pre-Application Meeting to discuss the proposed Site Improvements for Pod B1 & Pod B2 within the Master Development Plan for Village on the Green PD and to the commercial parcel (03-21-29-300-009M-0000) in the Sabal Point PD in Seminole County, FL.

Please see concept plan SP-01 that has been included with this submittal package. We believe the attached site plan will necessitate a Major Amendment to the Sabal Point PD and a Minor Amendment to the Village on the Green PD. Currently, parcel 03-21-29-300-009M-0000 contains one ± 67,820 SF building and accompanying parking lot slated for demolition. Our proposal includes developing a duplex community on the site. Additionally, the site plan incorporates a proposal for recreational use in tracts POD B1 and POD B2 within the Village on the Green PD.

The Proposed Development's Buildings have been oriented at least 20' away from the adjacent parcels and at least 25' away from the Right of Way along Wekiva Springs RD to adhere to the land development code and requirements of the Village on the Green PD creating reasonable screening. Stormwater management will be maintained by connecting our proposed site to the same stormwater pond the existing site is connected to.

This Pre-Application Meeting is being requested to specifically discuss the permitting processes and requirements for Seminole County approval of the proposed development.

If you have any questions or comments, please do not hesitate to contact us directly at (407) 427-1677 or by email at Brook.Stickler@Kimley-Horn.com.

Sincerely,

KIMLEY-HORN AND ASSOCIATES, INC.



Brooks A. Stickler, P.E.
Project Manager

"K:\ORL_Civil\249426000-Village on the Green Civil\AGENCY PERMITS\MUNICIPALITY\RECORD SUBMITTALS\Seminole County\Seminole County Pre-App Meeting (Cottages)\Village on the Green- Pre-Application Narrative.docx"

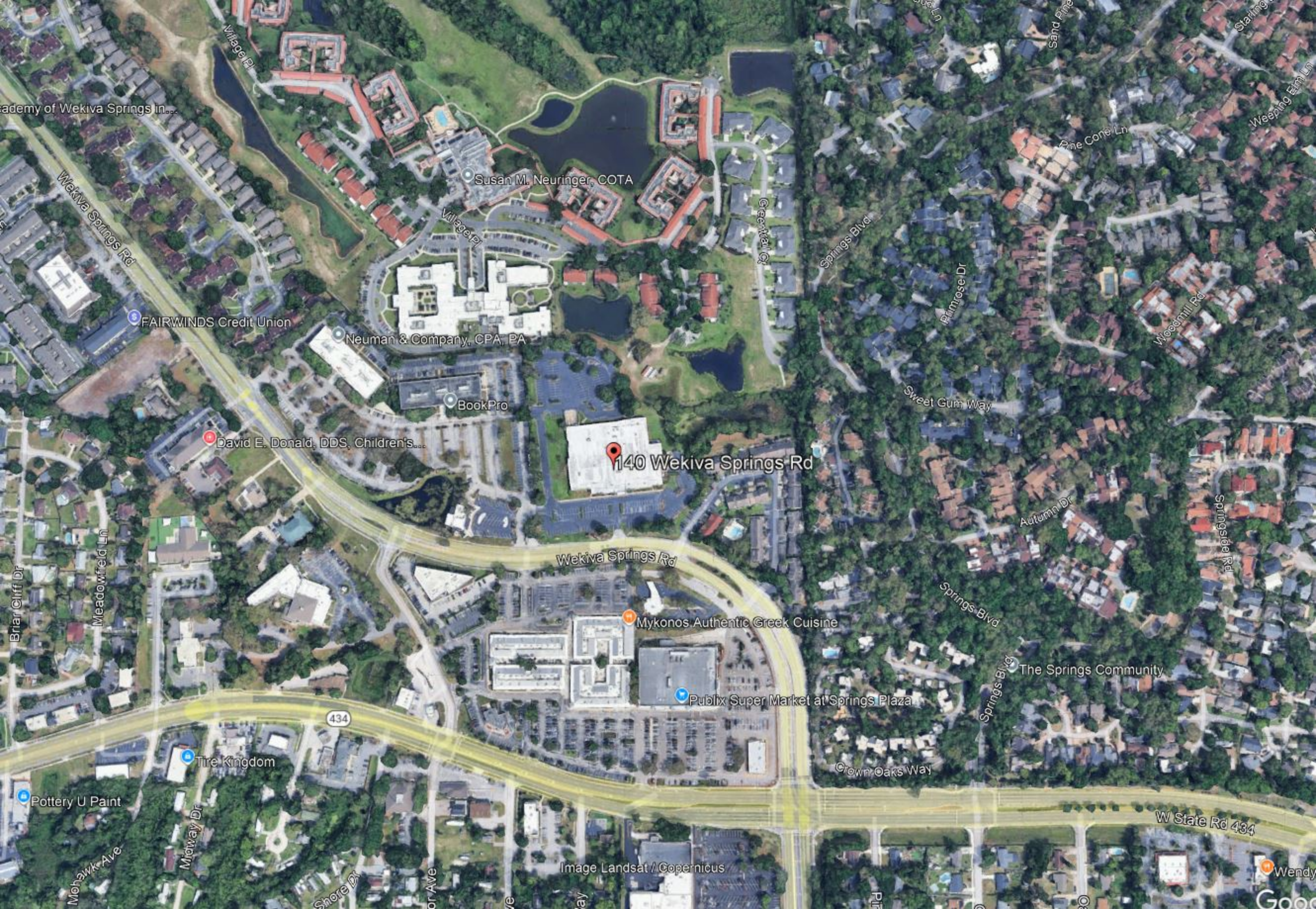

Academy of Wekiva Springs In...

Wekiva Springs Rd

Village Pl

Susan M. Neuringer, COTA

Village Pl

Central Ct

Springs Blvd

Pine Cone Ln

Weeping Elm Ln

FAIRWINDS Credit Union

Neuman & Company, CPA, PA

BookPro

David E. Donald, DDS, Children's...

140 Wekiva Springs Rd

Wekiva Springs Rd

Mykonos Authentic Greek Cuisine

Publix Super Market at Springs Plaza

The Springs Community

Springs Blvd

Autumn Dr

Springside Rd

Sweet Gum Way

Plumrose Dr

Woodmill Rd

Briar Cliff Dr

Meadowfield Ln

Tire Kingdom

Pottery U Paint

Miway Dr

Mohawk Ave

Shore Dr

or Ave

ve

Image Landsat / Copernicus

Crown Oaks Way

Springs Blvd

W State Rd 434

Wendy
Google

K:\ORL\Civil\249426000-Village on the Green Civil\CADD\XREF\BTS\2024-11-07-VOTG - Cottages\VOTG - Cottages - CSP - 2024-12-06.dwg



SITE DATA TABLE

PARCEL ID: 03-21-29-300-009M-0000
 EXISTING ZONING: PD (PLANNED DEVELOPMENT)
 FUTURE LAND USE: PD (PLANNED DEVELOPMENT)

AREA BREAKOUT
 GROSS PARCEL AREA: 6.94 AC
 NET/BUILDABLE AREA: 5.90 AC
 TOTAL POND AREA: 0.92 AC
 TOTAL OFFSITE AMENITY AREA: 2.55 AC
 PERCENTAGE POND (0.92/6.94): 13.3%

BUILDING SETBACKS:
 FRONT YARD: 25' (PER SABAL PALM PD)
 BACK YARD: 20' (PER SABAL PALM PD)
 SIDE YARD: 20' (PER SABAL PALM PD)

PROPOSED BUILDING COUNT:
 1500SF (SINGLE): 19 HOMES
 2000SF (SINGLE): 1 HOME
 2000SF (DUPLEX): 18 HOMES
 TOTAL: 38 HOMES

DENSITY:
 4.75 UNITS PER BUILDABLE ACRE (38 HOMES/5.90 AC)

PARCEL ID: 03-21-29-5WA-0000-0010
 EXISTING ZONING: PD (PLANNED DEVELOPMENT)
 FUTURE LAND USE: PD (PLANNED DEVELOPMENT)

BUILDING SETBACKS:
 FRONT YARD (NW ADJACENT SABAL PALM DR): 25' (PER VILLAGE ON THE GREEN PD)

BACK YARD (EAST): 25' (PER VILLAGE ON THE GREEN PD)

SIDE YARD (NW): 35' (PER VILLAGE ON THE GREEN PD)

SIDE YARD (SW): 25' (PER VILLAGE ON THE GREEN PD)

PROPOSED BUILDING COUNT:
 AMENITY BUILDING: 6000 SF

PROPOSED AMENITY FACILITIES:
 SPORTS COURTS: 4500 SF
 AMENITY FIELD SPACE: 5400 SF
 TOTAL: 15,900 SF

DISCLAIMER:
 THIS PLAN IS CONCEPTUAL AND SUBJECT TO CHANGE PER FINAL ENGINEERING AND JURISDICTIONAL REVIEW.

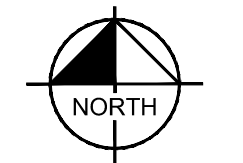
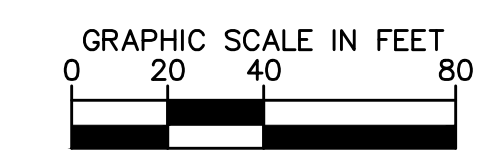

Kimley»Horn

VOTG COTTAGES

SP-01

LONGWOOD, FL

CONCEPTUAL SITE PLAN

11/20/2024 - CONTACT CAMERON PRISBY, E.I. (407) 789-2216

Property Record CardA



Parcel: **03-21-29-300-009M-0000**
 Property Address: **140 WEKIVA SPRINGS RD LONGWOOD, FL 32779**
 Owners: **ET LONGWOOD LLC**
 2025 Market Value \$8,740,520 Assessed Value \$8,740,520
 2024 Tax Bill \$115,136.38 Tax Savings with Non-Hx Cap \$1,314.84
 One Story Office Non-Prof property w/1st Building size of 67,125 SF and a lot size of 6.94 Acres

Parcel LocationA



Site ViewA



032129300009M0000 02/07/2024

Parcel InformationA

Parcel	03-21-29-300-009M-0000
Property Address	140 WEKIVA SPRINGS RD LONGWOOD, FL 32779
Mailing Address	8027 FORSYTH BLVD # 1100 SAINT LOUIS, MO 63105-1734
Subdivision	
Tax District	01:County Tax District
DOR Use Code	17:One Story Office Non-Prof
Exemptions	None
AG Classification	No

Value SummaryA

	2025 Working Values	2024 Certified Values
Valuation Method	Cost/Market	Cost/Market
Number of Buildings	1	1
Depreciated Building Value	\$6,303,333	\$6,390,275
Depreciated Other Features	\$161,723	\$150,312
Land Value (Market)	\$2,275,464	\$2,275,464
Land Value Agriculture	\$0	\$0
Just/Market Value	\$8,740,520	\$8,816,051
Portability Adjustment	\$0	\$0
Save Our Homes Adjustment/Maximum Portability	\$0	\$0
Non-Hx 10% Cap (AMD 1)	\$0	\$165,805
P&G Adjustment	\$0	\$0
Assessed Value	\$8,740,520	\$8,650,246

2024 Certified Tax SummaryA

Tax Amount w/o Exemptions	\$116,451.22
Tax Bill Amount	\$115,136.38
Tax Savings with Exemptions	\$1,314.84

Owner(s)A

Name - Ownership Type
 ET LONGWOOD LLC

Note: Does NOT INCLUDE Non Ad Valorem Assessments

Legal DescriptionA

SEC 03 TWP 21S RGE 29E
BEG 80.28 FT S OF 411.64 FT S 78
DEG 8 MIN 45 SEC W OF CENTER OF SEC
RUN S 17 DEG 18 MIN 5 SEC E 145.36
FT S 49 DEG 35 MIN 5 SEC W 182.54
FT S 68 DEG 12 MIN 5 SEC W 52.52 FT
WLY ON CURVE 108.31 FT S 84 DEG 01
MIN 53 SEC W 219.6 FT WLY ON CURVE
48 FT N 5 DEG 58 MIN 7 SEC W 98.9
FT N 17 DEG 54 MIN 08 SEC E 57.73
FT N 5 DEG 58 MIN 7 SEC W 525 FT N
84 DEG 38 MIN 2 SEC E 217.59 FT S
66 DEG 3 MIN 1 SEC E 98.64 FT S 17
DEG 42 MIN E 143.5 FT S 58 DEG 54
MIN E 214 FT S 17 DEG 18 MIN 5 SEC
E 108.92 FT TO BEG (LESS RD)

TaxesA

Taxing Authority	Assessed	Exempt Amount	Taxable
COUNTY GENERAL FUND	\$8,740,520	\$0	\$8,740,520
Schools	\$8,740,520	\$0	\$8,740,520
FIRE	\$8,740,520	\$0	\$8,740,520
ROAD DISTRICT	\$8,740,520	\$0	\$8,740,520
SJWM(Saint Johns Water Management)	\$8,740,520	\$0	\$8,740,520

SalesA

Deed Type	Date	Sale Amount	Book / Page	Sale Type	Qualified?
SPECIAL WARRANTY DEED	8/1/2015	\$10,370,300	08527/0570	Improved	No
SPECIAL WARRANTY DEED	10/1/2010	\$5,900,000	07471/1242	Improved	Yes
SPECIAL WARRANTY DEED	12/1/1999	\$6,000,000	03777/1501	Improved	No
WARRANTY DEED	5/1/1982	\$160,000	01402/1570	Improved	Yes

LandA

Units	Rate	Assessed	Market
297,058 SF	\$7.66/SF	\$2,275,464	\$2,275,464

Building InformationA	
#	1
Use	MASONRY PILASTER
Year Built*	1983/2000
Bed	
Bath	
Fixtures	0
Base Area (ft ²)	67125
Total Area (ft ²)	
Constuction	CONCRETE TILT UP - MASONRY
Replacement Cost	\$8,694,252
Assessed	\$6,303,333

* Year Built = Actual / Effective

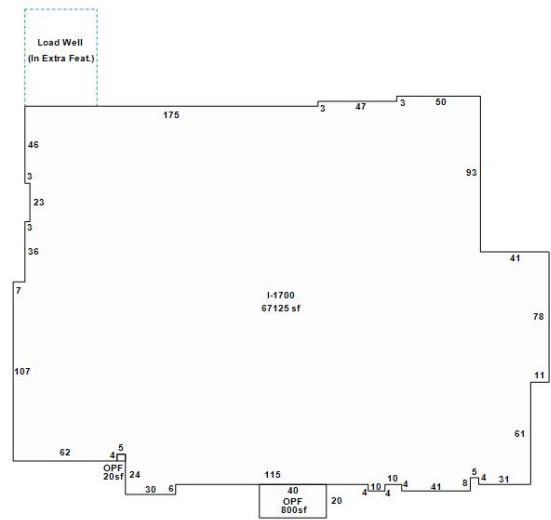

Building 1

AppendagesA	
Description	Area (ft ²)
OPEN PORCH FINISHED	800
OPEN PORCH FINISHED	20

PermitsA				
Permit #	Description	Value	CO Date	Permit Date
19378	140 WEKIVA SPRINGS RD: DEMO COMMERCIAL PARTIAL ROOF REPAIRS	\$2,400	8/23/2024	2/2/2024
19044	140 WEKIVA SPRINGS RD: ELECTRICAL - COMMERCIAL-building	\$3,000		12/15/2023
03338	140 WEKIVA SPRINGS RD: MECHANICAL - COMMERCIAL-One story office non-prof	\$21,875		3/19/2020
18104	FIRE ALARM ALTERATION - PAD	\$12,778		12/20/2017
10616	140 WEKIVA SPRINGS RD: MECHANICAL - COMMERCIAL-	\$100,000	4/20/2018	10/3/2017
10638	INTERIOR WORK	\$230,500	1/25/2018	8/3/2017
06212	ELECTRICAL	\$50,000		6/19/2017
04850	FIRE SPRINKLER	\$750		4/28/2016
03889	FIRE SPRINKLER SYSTEM INSTALLATION - SYNCHRONY FINANCIAL	\$5,000		4/8/2016
02029	MECHANICAL	\$4,880		2/27/2015
09460	ELECTRICAL	\$118,783		9/23/2014
08752	MECHANICAL	\$20,100		9/3/2014
08052	INTERIOR ALTERATION	\$3,200		8/15/2014
07345	CONCRETE UTILITY RAMP	\$12,000		7/25/2014
06895	ELECTRICAL	\$9,973		7/15/2014

03288	MECHANICAL	\$55,000		4/11/2014
08960	FIRE ALARM SYSTEM	\$850		10/24/2013
08961	FIRE SPRINKLER SYSTEM	\$1,540		10/24/2013
05955	INTERIOR ALTERATION	\$32,300		7/16/2013
08629	MECHANICAL	\$21,000		11/19/2012
05631	ELECTRICAL	\$1,200		7/26/2012
05113	ELECTRICAL	\$2,358		7/9/2012
04323	INSTALL 2.5 TON DUCTLESS SPLIT SYSTEM	\$6,799		6/8/2012
09633	ADD & RELOCATE 4 FIRE SPRINKLER HEADS TO ACCOMODATE NEW OFFICE LAY-OUT - GE CONSUMER SERVICES	\$750		12/20/2011
08953	ADD ADDITIONAL OFFICE SPACE, GENERAL ELECTRIC, ADD 2 WALKS, 3 DOORS, & 1 INT WINDOW	\$41,560		11/18/2011
08687	MECHANICAL	\$12,677		11/9/2011
08819	REROOF	\$158,900		11/12/2010
07825	REMODEL RESTROOMS - ADA ACCESSABLE	\$22,000		9/30/2010
07666	MECHANICAL	\$150,000		9/27/2010
06439	INSTALL FIRE SPRINKLERS	\$20,000		8/12/2010
06440	DRY CHEMICAL FIRE SYSTEM	\$150,000		8/12/2010
08611	INSTALL FIRE ALARM SYSTEM	\$37,521		8/2/2007
10881	ADDING 2 DOORS & 2 WALLS	\$3,700		11/1/2002
10890	FENCE/WALL	\$2,100		11/1/2002
10522	INSTALL FIRE ALARM SYSTEM	\$2,346		10/1/2002
05266	RANGEHOOD SUPPRESSION SYSTEM	\$0		5/1/2002
10671	ABOVE GROUND GAS TANKS	\$0		11/1/2001
09909	MECHANICAL & CONDENSOR	\$146,000		10/1/2001
03545	FIRE ALARM SYS	\$13,850		4/1/2001
03463	J.C.PENNEY'S INTERIOR RENOVATIONS	\$175,000	7/2/2001	4/1/2001
03278	INSTALL FIRE SPRINKLERS/MAIN	\$9,932		4/1/2001
05636	SIGN; PAD PER PERMIT 140 WEKIVA SRPINGS RD; CONTRACTOR - JAYCO SIGNS	\$0		6/19/2000
01901	BURGLAR ALARM; J C PENNEY CREDIT CENTER; PAD PER PERMIT 140 WEKIVA SPRINGS RD	\$14,600		3/1/1998
03993	INTERIOR REMODEL/ J C PENNY	\$49,000		6/1/1995
04255	J C PENNY CREDIT CENTER	\$1,268		6/1/1995
02067	J C PENNY BLDG ROLLED RUBBER	\$94,194		4/1/1995
06542	FIRE SPRINKLERS 140 WEKIVA SPRINGS RD	\$798		9/1/1994
06440	NO DESCRIP	\$43,580		9/1/1994

Extra FeaturesA				
Description	Year Built	Units	Cost	Assessed
COMMERCIAL ASPHALT DR 2 IN	1983	103400	\$263,670	\$105,468
WALKS CONC COMM	1983	6795	\$36,965	\$14,786
BLOCK WALL	1983	2760	\$38,281	\$15,312
POLE LIGHT 1 ARM	1983	13	\$24,102	\$24,102
LOAD WELL	1983	2494	\$5,138	\$2,055

ZoningA	
Zoning	PD
Description	Planned Development
Future Land Use	PD
Description	Planned Development

Political RepresentationA	
Commissioner	District 3 - Lee Constantine
US Congress	District 7 - Cory Mills
State House	District 39 - Doug Bankson
State Senate	District 10 - Jason Brodeur
Voting Precinct	Precinct 35

School DistrictsA	
Elementary	Sabal Point
Middle	Rock Lake
High	Lyman

UtilitiesA	
Fire Station #	Station: 16 Zone: 162
Power Company	DUKE
Phone (Analog)	CENTURY LINK
Water	Sunshine Water Services
Sewage	Sunshine Water Services
Garbage Pickup	
Recycle	
Yard Waste	
Hauler #	

Property Value HistoryA

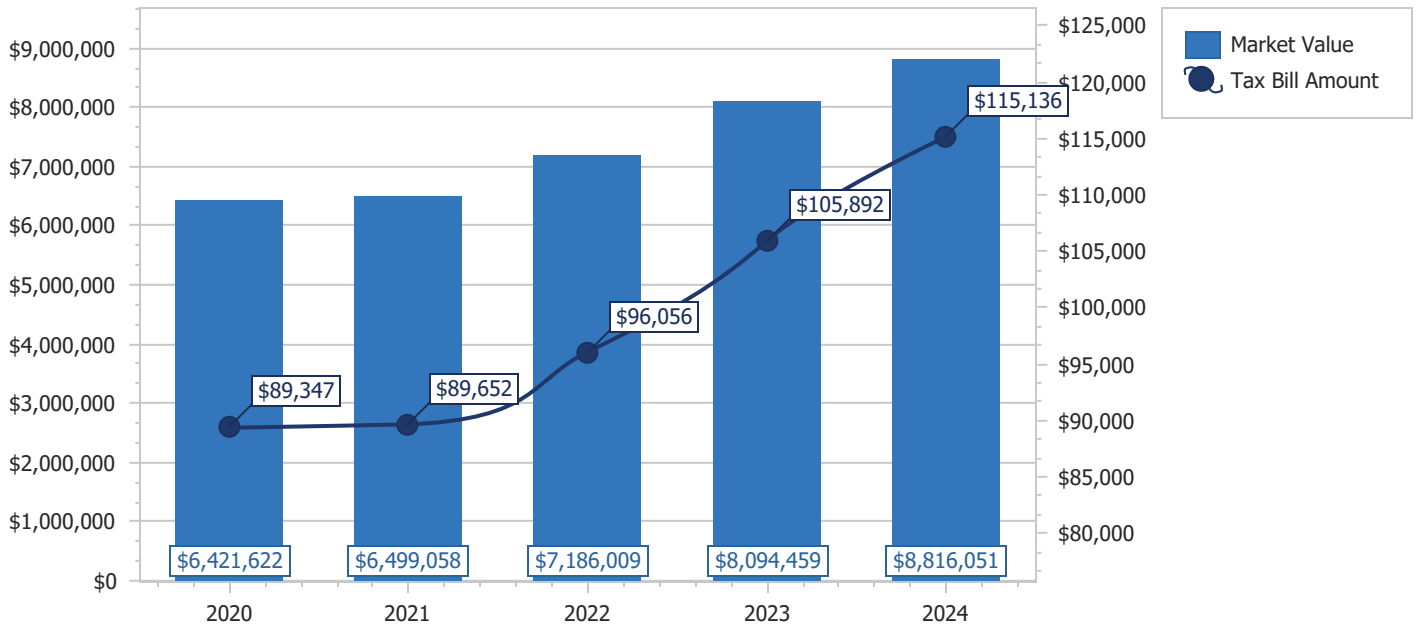

Copyright 2025 © Seminole County Property Appraiser

Property Record CardA



Parcel: **03-21-29-5WA-0000-0010**
 Property Address: **500 VILLAGE PL LONGWOOD, FL 32779**
 Owners: **LIFESPACE COMMUNITIES INC**
 2025 Market Value \$72,964,268 Assessed Value \$72,964,268
 2024 Tax Bill \$531,654.97 Tax Savings with Non-Hx Cap \$421,478.92
 Retirement Complex property w/1st Building size of 6,676 SF and a lot size of 75.97 Acres

Parcel LocationA

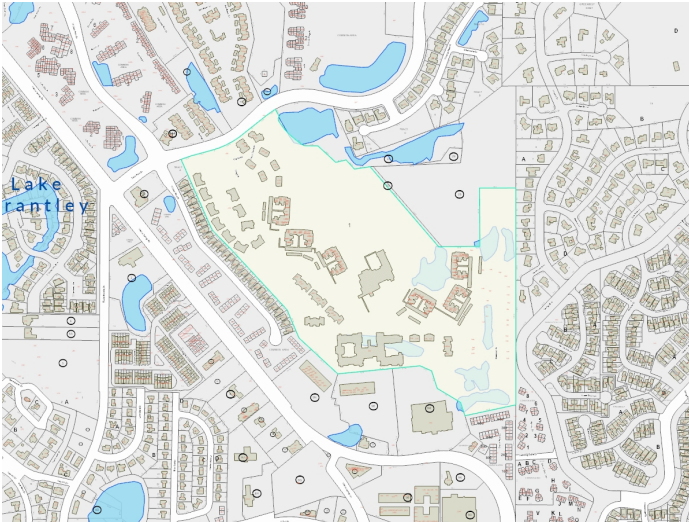

Site ViewA



Parcel InformationA

Parcel	03-21-29-5WA-0000-0010
Property Address	
Mailing Address	4201 CORPORATE DR WDM, IA 50266-5906
Subdivision	
Tax District	01:County Tax District
DOR Use Code	
Exemptions	40-HOME FOR AGED (2023)
AG Classification	

Value SummaryA

	2025 Working Values	2024 Certified Values
Valuation Method	Cost/Market	Cost/Market
Number of Buildings	32	32
Depreciated Building Value	\$61,292,863	\$60,587,814
Depreciated Other Features	\$844,158	\$742,853
Land Value (Market)	\$10,827,247	\$10,827,247
Land Value Agriculture	\$0	\$0
Just/Market Value	\$72,964,268	\$72,157,914
Portability Adjustment	\$0	\$0
Save Our Homes Adjustment/Maximum Portability	\$0	\$0
Non-Hx 10% Cap (AMD 1)	\$0	\$1,898,210
P&G Adjustment	\$0	\$0
Assessed Value	\$72,964,268	\$70,259,704

2024 Certified Tax SummaryA

Tax Amount w/o Exemptions	\$953,133.89
Tax Bill Amount	\$531,654.97
Tax Savings with Exemptions	\$421,478.92

Owner(s)A

Name - Ownership Type
 LIFESPACE COMMUNITIES INC

Note: Does NOT INCLUDE Non Ad Valorem Assessments

Legal DescriptionA

LOT 1
VILLAGE ON THE GREEN LONGWOOD
PB 88 PGS 63-69

TaxesA

Taxing Authority	Assessed	Exempt Amount	Taxable
COUNTY GENERAL FUND	\$72,964,268	\$30,768,878	\$42,195,390
Schools	\$72,964,268	\$30,768,878	\$42,195,390
FIRE	\$72,964,268	\$30,768,878	\$42,195,390
ROAD DISTRICT	\$72,964,268	\$30,768,878	\$42,195,390
SJWM(Saint Johns Water Management)	\$72,964,268	\$30,768,878	\$42,195,390

SalesA

Deed Type	Date	Sale Amount	Book / Page	Sale Type	Qualified?
-----------	------	-------------	-------------	-----------	------------

LandA

Units	Rate	Assessed	Market
999,999 SF	\$3.50/SF	\$3,499,997	\$3,499,997
999,999 SF	\$3.50/SF	\$3,499,997	\$3,499,997
999,999 SF	\$3.50/SF	\$3,499,997	\$3,499,997
93,374 SF	\$3.50/SF	\$326,809	\$326,809
3.83 Acres	\$116.60/Acre	\$447	\$447

Building InformationA

#	1
Use	MULTIFAMILY
Year Built*	1986
Bed	
Bath	
Fixtures	0
Base Area (ft ²)	6676
Total Area (ft ²)	
Constuction	BRICK COMMON - MASONRY
Replacement Cost	\$901,421
Assessed	\$734,658

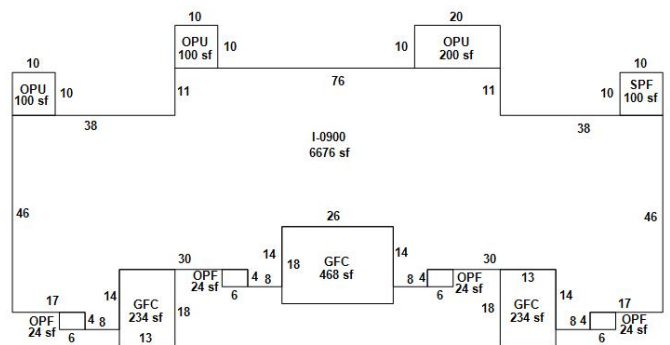

Building 1

* Year Built = Actual / Effective

AppendagesA

Description	Area (ft ²)
GARAGE FINISHED C.B.S.	234
GARAGE FINISHED C.B.S.	234
GARAGE FINISHED C.B.S.	468
OPEN PORCH FINISHED	24
OPEN PORCH FINISHED	24
OPEN PORCH FINISHED	24
OPEN PORCH FINISHED	24
OPEN PORCH UNFINISHED	200
OPEN PORCH UNFINISHED	100
OPEN PORCH UNFINISHED	100
SCREEN PORCH FINISHED	100

Building InformationA

#	2
Use	MULTIFAMILY
Year Built*	1986
Bed	
Bath	
Fixtures	0
Base Area (ft ²)	6676
Total Area (ft ²)	
Constuction	BRICK COMMON - MASONRY
Replacement Cost	\$898,974
Assessed	\$732,664

* Year Built = Actual / Effective

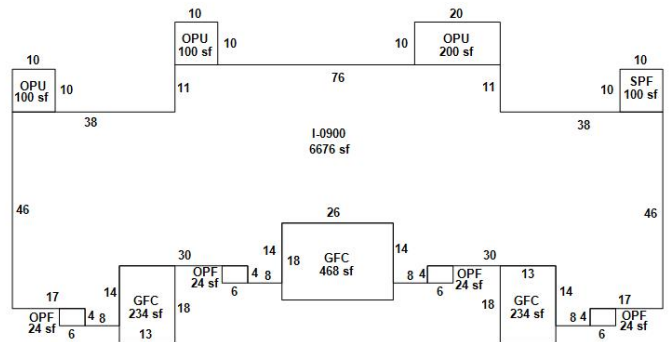

Building 2

AppendagesA

Description	Area (ft ²)
GARAGE FINISHED C.B.S.	234
GARAGE FINISHED C.B.S.	234
GARAGE FINISHED C.B.S.	468
OPEN PORCH FINISHED	24
OPEN PORCH FINISHED	24
OPEN PORCH FINISHED	24
OPEN PORCH FINISHED	24
OPEN PORCH UNFINISHED	100

OPEN PORCH UNFINISHED	100
OPEN PORCH UNFINISHED	100
OPEN PORCH UNFINISHED	100

Building InformationA	
#	3
Use	MULTIFAMILY
Year Built*	1986
Bed	
Bath	
Fixtures	0
Base Area (ft ²)	6676
Total Area (ft ²)	
Constuction	BRICK COMMON - MASONRY
Replacement Cost	\$906,748
Assessed	\$739,000

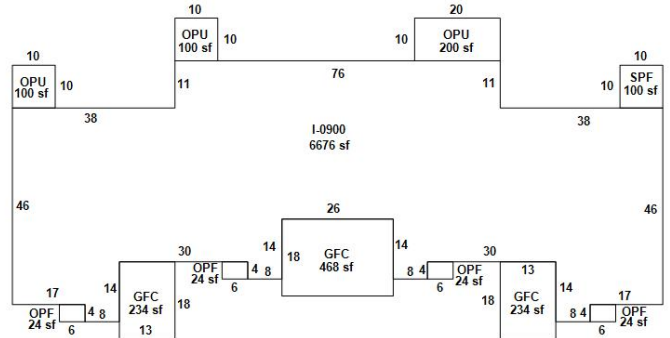

Building 3

* Year Built = Actual / Effective

AppendagesA	
Description	Area (ft ²)
GARAGE FINISHED C.B.S.	468
GARAGE FINISHED C.B.S.	234
GARAGE FINISHED C.B.S.	234
OPEN PORCH FINISHED	24
OPEN PORCH FINISHED	24
OPEN PORCH FINISHED	24
OPEN PORCH FINISHED	24
OPEN PORCH UNFINISHED	200
OPEN PORCH UNFINISHED	100
OPEN PORCH UNFINISHED	200
SCREEN PORCH FINISHED	250

Building InformationA	
#	4
Use	MULTIFAMILY
Year Built*	1986
Bed	
Bath	
Fixtures	0
Base Area (ft ²)	6676
Total Area (ft ²)	
Constuction	BRICK COMMON - MASONRY
Replacement Cost	\$921,955
Assessed	\$751,393

* Year Built = Actual / Effective

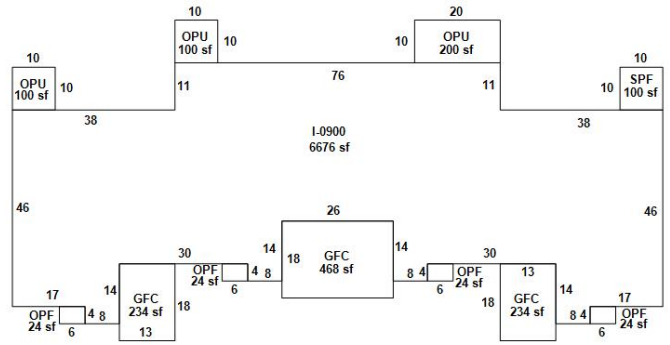

Building 4

AppendagesA	
Description	Area (ft ²)
ENCLOSED PORCH FINISHED	300
GARAGE FINISHED C.B.S.	234
GARAGE FINISHED C.B.S.	468
GARAGE FINISHED C.B.S.	234
OPEN PORCH FINISHED	24
OPEN PORCH FINISHED	24
OPEN PORCH FINISHED	24
OPEN PORCH FINISHED	24
SCREEN PORCH FINISHED	260
SCREEN PORCH FINISHED	260
SCREEN PORCH FINISHED	250

Building InformationA	
#	6
Use	MULTIFAMILY
Year Built*	1986
Bed	
Bath	
Fixtures	0
Base Area (ft ²)	32859
Total Area (ft ²)	
Constuction	BRICK COMMON - MASONRY
Replacement Cost	\$4,018,031
Assessed	\$3,274,695

* Year Built = Actual / Effective

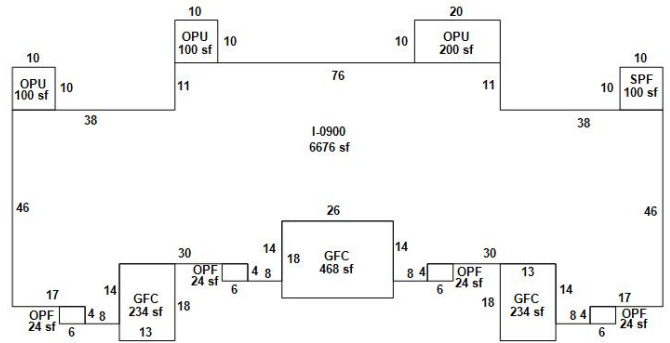

Building 6

AppendagesA	
Description	Area (ft ²)
CANOPY DETACHED	2680
CARPORT FINISHED	4840
ENCLOSED PORCH FINISHED	251
ENCLOSED PORCH FINISHED	160
ENCLOSED PORCH FINISHED	176
ENCLOSED PORCH FINISHED	192
ENCLOSED PORCH FINISHED	160
ENCLOSED PORCH FINISHED	160
ENCLOSED PORCH FINISHED	224
ENCLOSED PORCH FINISHED	176
ENCLOSED PORCH FINISHED	160
ENCLOSED PORCH FINISHED	160
ENCLOSED PORCH FINISHED	96
ENCLOSED PORCH FINISHED	96
ENCLOSED PORCH FINISHED	112
ENCLOSED PORCH FINISHED	251
ENCLOSED PORCH FINISHED	160
ENCLOSED PORCH FINISHED	176
ENCLOSED PORCH FINISHED	192
ENCLOSED PORCH FINISHED	160
ENCLOSED PORCH FINISHED	283
ENCLOSED PORCH FINISHED	160

ENCLOSED PORCH FINISHED	96
ENCLOSED PORCH FINISHED	96
ENCLOSED PORCH FINISHED	112
ENCLOSED PORCH FINISHED	160
ENCLOSED PORCH FINISHED	224
ENCLOSED PORCH FINISHED	176
ENCLOSED PORCH FINISHED	192
ENCLOSED PORCH FINISHED	160
ENCLOSED PORCH FINISHED	283
ENCLOSED PORCH FINISHED	176
ENCLOSED PORCH FINISHED	160
ENCLOSED PORCH FINISHED	96
ENCLOSED PORCH FINISHED	112
ENCLOSED PORCH FINISHED	160
ENCLOSED PORCH FINISHED	224
ENCLOSED PORCH FINISHED	251
ENCLOSED PORCH FINISHED	160
ENCLOSED PORCH FINISHED	283
ENCLOSED PORCH FINISHED	176
ENCLOSED PORCH FINISHED	160
ENCLOSED PORCH FINISHED	160
ENCLOSED PORCH FINISHED	96
ENCLOSED PORCH FINISHED	580
OPEN PORCH FINISHED	4077
OPEN PORCH FINISHED	383
OPEN PORCH FINISHED	1528
OPEN PORCH FINISHED	1528
OPEN PORCH UNFINISHED	405
OPEN PORCH UNFINISHED	963
UTILITY FINISHED	56
UTILITY FINISHED	64
UTILITY FINISHED	64
UTILITY FINISHED	64
UTILITY FINISHED	32
UTILITY FINISHED	64
UTILITY FINISHED	170
UTILITY FINISHED	170
UTILITY FINISHED	64
UTILITY FINISHED	32
UTILITY FINISHED	32

UTILITY FINISHED	56
UTILITY FINISHED	64
UTILITY FINISHED	64
UTILITY FINISHED	64
UTILITY FINISHED	56
UTILITY FINISHED	56
UTILITY FINISHED	32
UTILITY FINISHED	64
UTILITY FINISHED	170
UTILITY FINISHED	170
UTILITY FINISHED	64
UTILITY FINISHED	64
UTILITY FINISHED	32
UTILITY FINISHED	56
UTILITY FINISHED	64
UTILITY FINISHED	64
UTILITY FINISHED	64
UTILITY FINISHED	56
UTILITY FINISHED	32
UTILITY FINISHED	64
UTILITY FINISHED	170
UTILITY FINISHED	405
UTILITY FINISHED	170
UTILITY UNFINISHED	108
UTILITY UNFINISHED	108
UTILITY UNFINISHED	204
UTILITY UNFINISHED	108
UTILITY UNFINISHED	108
UTILITY UNFINISHED	204
UTILITY UNFINISHED	108
UTILITY UNFINISHED	108
UTILITY UNFINISHED	204

ENCLOSED PORCH FINISHED	160
ENCLOSED PORCH FINISHED	160
ENCLOSED PORCH FINISHED	283
ENCLOSED PORCH FINISHED	176
ENCLOSED PORCH FINISHED	160
ENCLOSED PORCH FINISHED	160
ENCLOSED PORCH FINISHED	96
ENCLOSED PORCH FINISHED	160
ENCLOSED PORCH FINISHED	224
ENCLOSED PORCH FINISHED	251
ENCLOSED PORCH FINISHED	160
ENCLOSED PORCH FINISHED	176
ENCLOSED PORCH FINISHED	192
ENCLOSED PORCH FINISHED	160
ENCLOSED PORCH FINISHED	160
ENCLOSED PORCH FINISHED	96
ENCLOSED PORCH FINISHED	580
ENCLOSED PORCH FINISHED	96
ENCLOSED PORCH FINISHED	112
ENCLOSED PORCH FINISHED	160
ENCLOSED PORCH FINISHED	176
ENCLOSED PORCH FINISHED	192
ENCLOSED PORCH FINISHED	160
ENCLOSED PORCH FINISHED	283
ENCLOSED PORCH FINISHED	176
OPEN PORCH FINISHED	5923
OPEN PORCH FINISHED	383
OPEN PORCH FINISHED	1528
OPEN PORCH FINISHED	1528
OPEN PORCH UNFINISHED	405
OPEN PORCH UNFINISHED	963
UTILITY FINISHED	170
UTILITY FINISHED	170
UTILITY FINISHED	64
UTILITY FINISHED	32
UTILITY FINISHED	64
UTILITY FINISHED	64
UTILITY FINISHED	64
UTILITY FINISHED	56
UTILITY FINISHED	32

UTILITY FINISHED	64
UTILITY FINISHED	64
UTILITY FINISHED	170
UTILITY FINISHED	170
UTILITY FINISHED	64
UTILITY FINISHED	32
UTILITY FINISHED	56
UTILITY FINISHED	56
UTILITY FINISHED	64
UTILITY FINISHED	64
UTILITY FINISHED	64
UTILITY FINISHED	56
UTILITY FINISHED	32
UTILITY FINISHED	64
UTILITY FINISHED	170
UTILITY FINISHED	405
UTILITY FINISHED	170
UTILITY FINISHED	64
UTILITY FINISHED	32
UTILITY FINISHED	56
UTILITY FINISHED	64
UTILITY FINISHED	64
UTILITY FINISHED	64
UTILITY FINISHED	56
UTILITY FINISHED	32
UTILITY UNFINISHED	108
UTILITY UNFINISHED	108
UTILITY UNFINISHED	204
UTILITY UNFINISHED	204
UTILITY UNFINISHED	108
UTILITY UNFINISHED	108
UTILITY UNFINISHED	204
UTILITY UNFINISHED	108
UTILITY UNFINISHED	108

Building InformationA	
#	8
Use	MULTIFAMILY
Year Built*	1986
Bed	
Bath	
Fixtures	0
Base Area (ft ²)	32859
Total Area (ft ²)	
Constuction	BRICK COMMON - MASONRY
Replacement Cost	\$4,016,230
Assessed	\$3,273,227

* Year Built = Actual / Effective

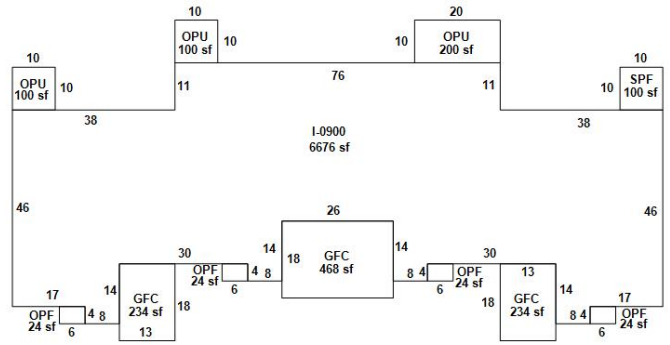

Building 8

AppendagesA	
Description	Area (ft ²)
CANOPY DETACHED	2000
CANOPY DETACHED	2160
CARPORT FINISHED	3800
ENCLOSED PORCH FINISHED	251
ENCLOSED PORCH FINISHED	160
ENCLOSED PORCH FINISHED	176
ENCLOSED PORCH FINISHED	160
ENCLOSED PORCH FINISHED	283
ENCLOSED PORCH FINISHED	176
ENCLOSED PORCH FINISHED	160
ENCLOSED PORCH FINISHED	160
ENCLOSED PORCH FINISHED	96
ENCLOSED PORCH FINISHED	160
ENCLOSED PORCH FINISHED	224
ENCLOSED PORCH FINISHED	251
ENCLOSED PORCH FINISHED	160
ENCLOSED PORCH FINISHED	176
ENCLOSED PORCH FINISHED	192
ENCLOSED PORCH FINISHED	176
ENCLOSED PORCH FINISHED	160
ENCLOSED PORCH FINISHED	160
ENCLOSED PORCH FINISHED	96

ENCLOSED PORCH FINISHED	96
ENCLOSED PORCH FINISHED	112
ENCLOSED PORCH FINISHED	251
ENCLOSED PORCH FINISHED	160
ENCLOSED PORCH FINISHED	176
ENCLOSED PORCH FINISHED	192
ENCLOSED PORCH FINISHED	160
ENCLOSED PORCH FINISHED	283
ENCLOSED PORCH FINISHED	96
ENCLOSED PORCH FINISHED	580
ENCLOSED PORCH FINISHED	96
ENCLOSED PORCH FINISHED	112
ENCLOSED PORCH FINISHED	160
ENCLOSED PORCH FINISHED	224
ENCLOSED PORCH FINISHED	192
ENCLOSED PORCH FINISHED	160
ENCLOSED PORCH FINISHED	283
ENCLOSED PORCH FINISHED	176
ENCLOSED PORCH FINISHED	160
ENCLOSED PORCH FINISHED	160
ENCLOSED PORCH FINISHED	96
ENCLOSED PORCH FINISHED	112
ENCLOSED PORCH FINISHED	160
ENCLOSED PORCH FINISHED	224
OPEN PORCH FINISHED	4693
OPEN PORCH FINISHED	383
OPEN PORCH FINISHED	1528
OPEN PORCH FINISHED	1528
OPEN PORCH UNFINISHED	405
OPEN PORCH UNFINISHED	963
UTILITY FINISHED	56
UTILITY FINISHED	64
UTILITY FINISHED	64
UTILITY FINISHED	32
UTILITY FINISHED	64
UTILITY FINISHED	56
UTILITY FINISHED	32
UTILITY FINISHED	64
UTILITY FINISHED	170
UTILITY FINISHED	170

UTILITY FINISHED	170
UTILITY FINISHED	64
UTILITY FINISHED	32
UTILITY FINISHED	56
UTILITY FINISHED	64
UTILITY FINISHED	64
UTILITY FINISHED	64
UTILITY FINISHED	64
UTILITY FINISHED	56
UTILITY FINISHED	32
UTILITY FINISHED	64
UTILITY FINISHED	170
UTILITY FINISHED	405
UTILITY FINISHED	170
UTILITY FINISHED	64
UTILITY FINISHED	32
UTILITY FINISHED	56
UTILITY FINISHED	64
UTILITY FINISHED	64
UTILITY FINISHED	64
UTILITY FINISHED	56
UTILITY FINISHED	32
UTILITY FINISHED	64
UTILITY FINISHED	170
UTILITY UNFINISHED	108
UTILITY UNFINISHED	204
UTILITY UNFINISHED	108
UTILITY UNFINISHED	108
UTILITY UNFINISHED	204
UTILITY UNFINISHED	108
UTILITY UNFINISHED	108
UTILITY UNFINISHED	204
UTILITY UNFINISHED	108

UTILITY UNFINISHED	204
UTILITY UNFINISHED	108
UTILITY UNFINISHED	108
UTILITY UNFINISHED	204
UTILITY UNFINISHED	108

Building InformationA	
#	10
Use	MASONRY PILASTER .
Year Built*	1986/2010
Bed	
Bath	
Fixtures	0
Base Area (ft ²)	36843
Total Area (ft ²)	
Constuction	BRICK COMMON - MASONRY
Replacement Cost	\$4,602,774
Assessed	\$3,797,289

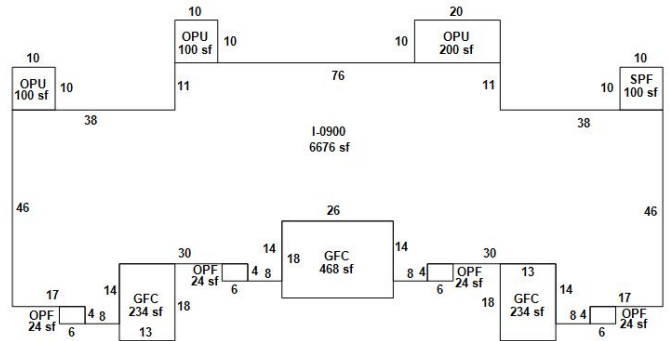

Building 10

* Year Built = Actual / Effective

AppendagesA	
Description	Area (ft ²)
CARPORT FINISHED	784
CARPORT FINISHED	462
ENCLOSED PORCH FINISHED	414
OPEN PORCH FINISHED	1463
OPEN PORCH FINISHED	64
OPEN PORCH FINISHED	921
OPEN PORCH FINISHED	150
OPEN PORCH FINISHED	1400
OPEN PORCH FINISHED	2065
OPEN PORCH FINISHED	513
OPEN PORCH FINISHED	1546
OPEN PORCH FINISHED	64
SCREEN PORCH FINISHED	252
UTILITY FINISHED	1053
UTILITY FINISHED	1393
UTILITY UNFINISHED	320

Building InformationA	
#	11
Use	MULTIFAMILY
Year Built*	1989
Bed	
Bath	
Fixtures	0
Base Area (ft ²)	42324
Total Area (ft ²)	
Constuction	BRICK COMMON - MASONRY
Replacement Cost	\$4,628,735
Assessed	\$3,876,566

* Year Built = Actual / Effective

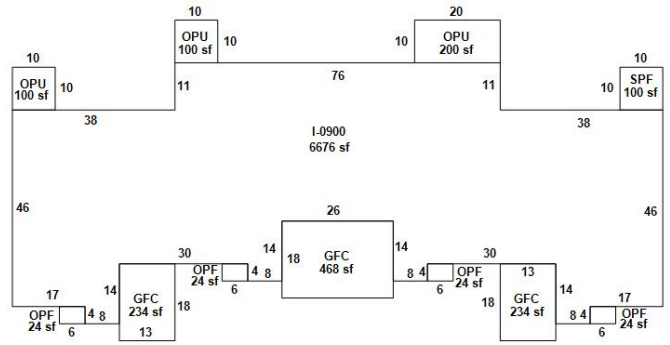

Building 11

AppendagesA	
Description	Area (ft ²)
CANOPY DETACHED	1600
CANOPY DETACHED	2400
CARPORT FINISHED	4180
ENCLOSED PORCH FINISHED	580
ENCLOSED PORCH FINISHED	580
OPEN PORCH FINISHED	5988
OPEN PORCH FINISHED	2942
OPEN PORCH FINISHED	2942
OPEN PORCH FINISHED	580
UTILITY FINISHED	170
UTILITY FINISHED	204
UTILITY FINISHED	405
UTILITY FINISHED	170
UTILITY FINISHED	204
UTILITY FINISHED	405
UTILITY FINISHED	170
UTILITY FINISHED	204
UTILITY FINISHED	405
UTILITY UNFINISHED	108
UTILITY UNFINISHED	108
UTILITY UNFINISHED	204
UTILITY UNFINISHED	108

UTILITY UNFINISHED	108
UTILITY UNFINISHED	204
UTILITY UNFINISHED	108
UTILITY UNFINISHED	108
UTILITY UNFINISHED	204

Building InformationA	
#	12
Use	MULTIFAMILY
Year Built*	1989
Bed	
Bath	
Fixtures	0
Base Area (ft ²)	42324
Total Area (ft ²)	
Constuction	BRICK COMMON - MASONRY
Replacement Cost	\$4,611,791
Assessed	\$3,862,375

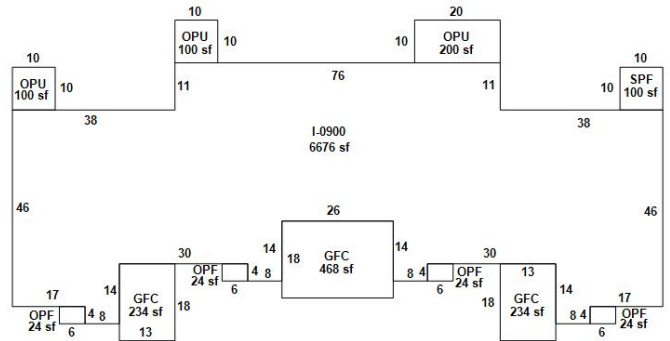

Building 12

* Year Built = Actual / Effective

AppendagesA	
Description	Area (ft ²)
CANOPY DETACHED	1400
CANOPY DETACHED	1200
CARPORT FINISHED	4180
ENCLOSED PORCH FINISHED	580
ENCLOSED PORCH FINISHED	580
OPEN PORCH FINISHED	5568
OPEN PORCH FINISHED	2942
OPEN PORCH FINISHED	2942
OPEN PORCH FINISHED	580
UTILITY FINISHED	170
UTILITY FINISHED	204
UTILITY FINISHED	405
UTILITY FINISHED	170
UTILITY FINISHED	204
UTILITY FINISHED	405
UTILITY FINISHED	170
UTILITY FINISHED	204

UTILITY UNFINISHED 108

UTILITY UNFINISHED 204

UTILITY UNFINISHED 108

UTILITY UNFINISHED 108

UTILITY UNFINISHED 204

Building InformationA	
#	13
Use	MULTIFAMILY
Year Built*	1989
Bed	
Bath	
Fixtures	0
Base Area (ft ²)	2550
Total Area (ft ²)	
Constuction	WOOD SIDING WITH WOOD OR METAL STUDS
Replacement Cost	\$321,150
Assessed	\$268,963

* Year Built = Actual / Effective

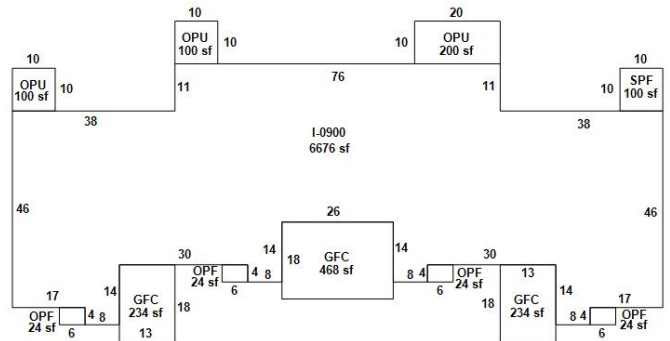

Building 13

AppendagesA	
Description	Area (ft ²)
GARAGE FINISHED C.B.S.	990
OPEN PORCH FINISHED	18
OPEN PORCH FINISHED	18

Building InformationA	
#	14
Use	MULTIFAMILY
Year Built*	1989
Bed	
Bath	
Fixtures	0
Base Area (ft ²)	2550
Total Area (ft ²)	
Constuction	WOOD SIDING WITH WOOD OR METAL STUDS
Replacement Cost	\$321,150
Assessed	\$268,963

* Year Built = Actual / Effective

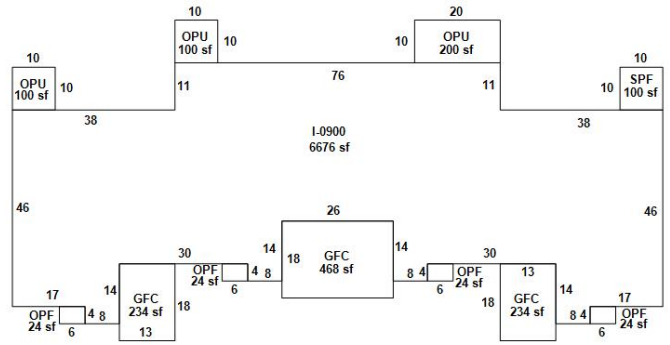

Building 14

AppendagesA	
Description	Area (ft ²)
GARAGE FINISHED C.B.S.	990
OPEN PORCH FINISHED	18

Building InformationA	
#	15
Use	MULTIFAMILY
Year Built*	1989
Bed	
Bath	
Fixtures	0
Base Area (ft ²)	2550
Total Area (ft ²)	
Constuction	WOOD SIDING WITH WOOD OR METAL STUDS
Replacement Cost	\$321,150
Assessed	\$268,963

* Year Built = Actual / Effective

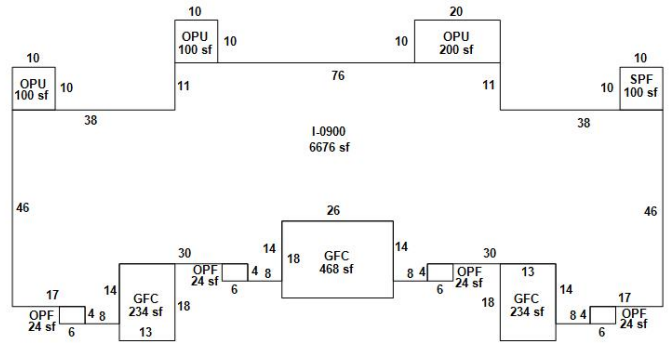

Building 15

AppendagesA	
Description	Area (ft ²)

OPEN PORCH FINISHED

18

Building InformationA	
#	16
Use	MULTIFAMILY
Year Built*	1989
Bed	
Bath	
Fixtures	0
Base Area (ft ²)	2550
Total Area (ft ²)	
Constuction	WOOD SIDING WITH WOOD OR METAL STUDS
Replacement Cost	\$361,294
Assessed	\$302,584

* Year Built = Actual / Effective

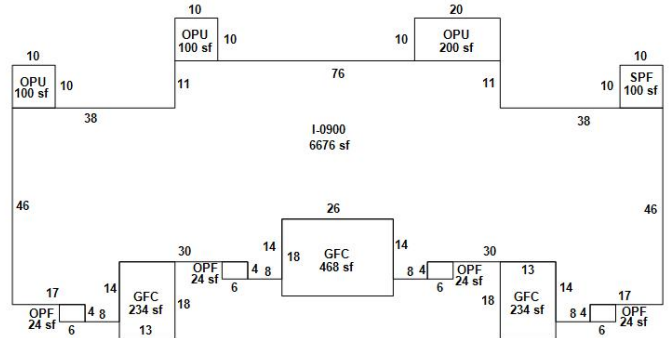

Building 16

AppendagesA	
Description	Area (ft ²)
GARAGE FINISHED C.B.S.	990
OPEN PORCH FINISHED	18
OPEN PORCH FINISHED	18

Building InformationA	
#	17
Use	MULTIFAMILY
Year Built*	1989
Bed	
Bath	
Fixtures	0
Base Area (ft ²)	2550
Total Area (ft ²)	
Constuction	WOOD SIDING WITH WOOD OR METAL STUDS
Replacement Cost	\$361,294
Assessed	\$302,584

* Year Built = Actual / Effective

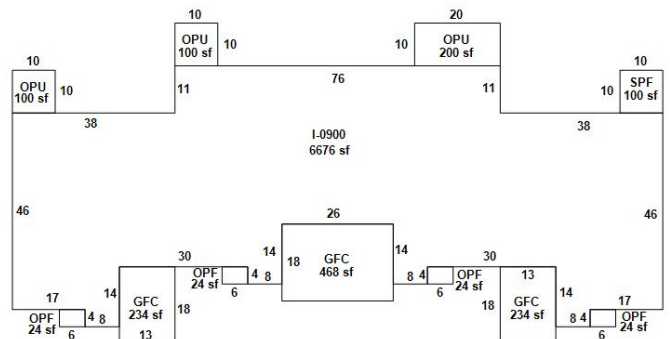

Building 17

Building InformationA	
#	19
Use	MULTIFAMILY
Year Built*	1996
Bed	
Bath	
Fixtures	0
Base Area (ft ²)	5436
Total Area (ft ²)	
Constuction	WOOD SIDING WITH WOOD OR METAL STUDS
Replacement Cost	\$656,717
Assessed	\$581,195

* Year Built = Actual / Effective

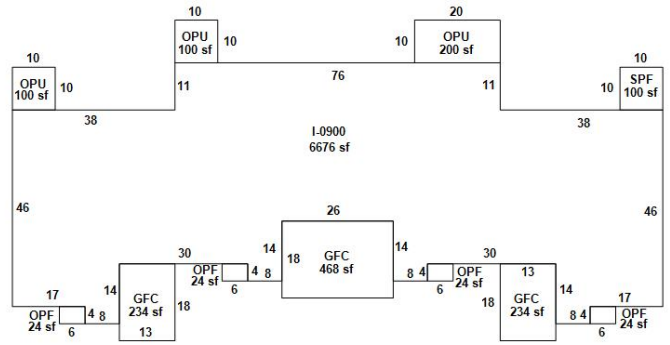

Building 19

AppendagesA	
Description	Area (ft ²)
GARAGE FINISHED WOOD	700
OPEN PORCH FINISHED	72
OPEN PORCH FINISHED	72
SCREEN PORCH FINISHED	154
SCREEN PORCH FINISHED	154

Building InformationA	
#	20
Use	MULTIFAMILY
Year Built*	1996
Bed	
Bath	
Fixtures	0
Base Area (ft ²)	4024
Total Area (ft ²)	
Constuction	WOOD SIDING WITH WOOD OR METAL STUDS
Replacement Cost	\$541,936
Assessed	\$479,613

* Year Built = Actual / Effective

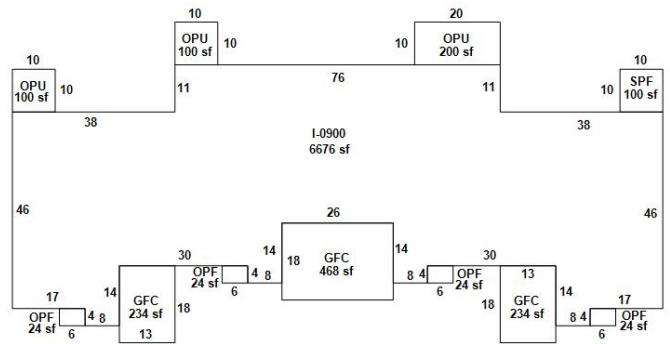

Building 20

AppendagesA

Description	Area (ft ²)
GARAGE FINISHED WOOD	1150
OPEN PORCH FINISHED	90
SCREEN PORCH FINISHED	165

Building InformationA

#	21
Use	MULTIFAMILY
Year Built*	1989
Bed	
Bath	
Fixtures	0
Base Area (ft ²)	3238
Total Area (ft ²)	
Constuction	WOOD SIDING WITH WOOD OR METAL STUDS
Replacement Cost	\$412,314
Assessed	\$345,313

* Year Built = Actual / Effective

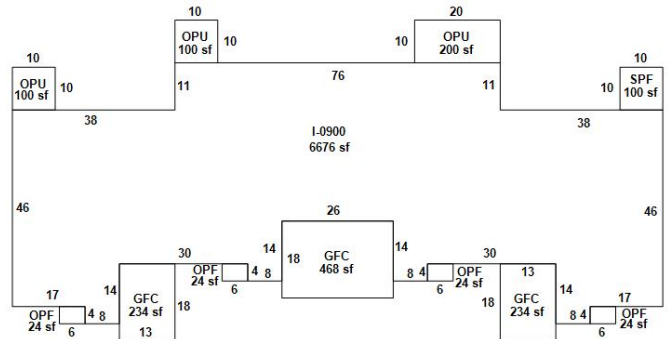

Building 21

AppendagesA

Description	Area (ft ²)
GARAGE FINISHED WOOD	598
OPEN PORCH FINISHED	30
OPEN PORCH FINISHED	30

Building InformationA	
#	22
Use	REINFORCED CONCRETE
Year Built*	2021
Bed	
Bath	
Fixtures	0
Base Area (ft ²)	99333
Total Area (ft ²)	
Constuction	CONCRETE TILT UP - MASONRY
Replacement Cost	\$24,420,212
Assessed	\$23,687,606

* Year Built = Actual / Effective

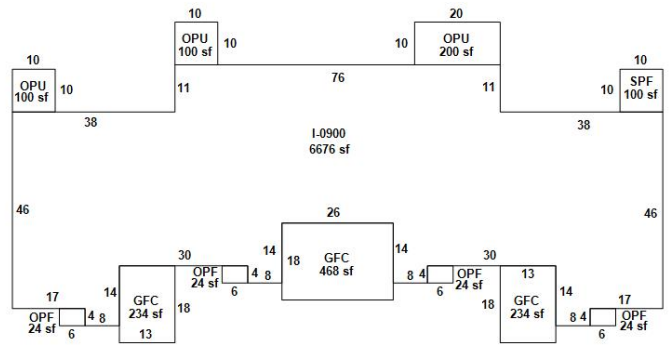

Building 22

AppendagesA	
Description	Area (ft ²)
CANOPY	966
OPEN PORCH FINISHED	276
OPEN PORCH FINISHED	293
OPEN PORCH FINISHED	68
OPEN PORCH FINISHED	407
OPEN PORCH FINISHED	52

Building InformationA	
#	23
Use	MULTIFAMILY
Year Built*	2021
Bed	
Bath	
Fixtures	0
Base Area (ft ²)	3688
Total Area (ft ²)	
Constuction	CONCRETE BLOCK-STUCCO - MASONRY
Replacement Cost	\$578,663
Assessed	\$569,983

* Year Built = Actual / Effective

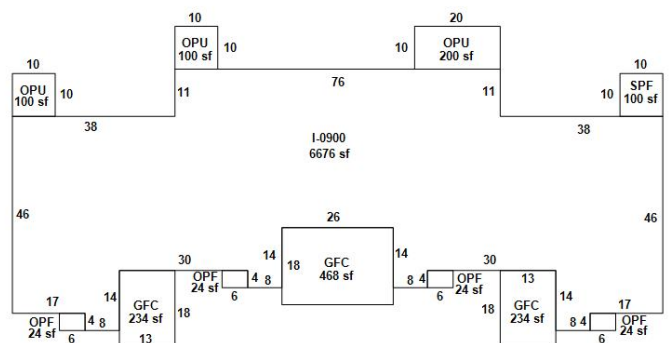

Building 23

Building InformationA	
#	25
Use	MULTIFAMILY
Year Built*	2021
Bed	
Bath	
Fixtures	0
Base Area (ft ²)	3688
Total Area (ft ²)	
Constuction	CONCRETE BLOCK-STUCCO - MASONRY
Replacement Cost	\$575,640
Assessed	\$567,005

* Year Built = Actual / Effective

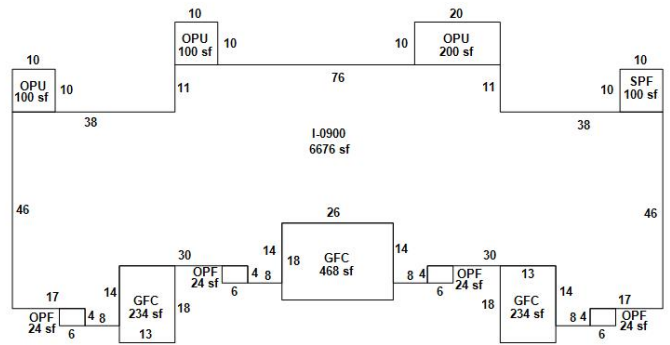

Building 25

AppendagesA	
Description	Area (ft ²)
GARAGE FINISHED C.B.S.	529
GARAGE FINISHED C.B.S.	529
OPEN PORCH FINISHED	350
OPEN PORCH FINISHED	104
OPEN PORCH FINISHED	105
OPEN PORCH FINISHED	261

Building InformationA	
#	26
Use	MULTIFAMILY
Year Built*	2021
Bed	
Bath	
Fixtures	0
Base Area (ft ²)	4218
Total Area (ft ²)	
Constuction	CONCRETE BLOCK-STUCCO - MASONRY
Replacement Cost	\$623,805
Assessed	\$614,448

* Year Built = Actual / Effective

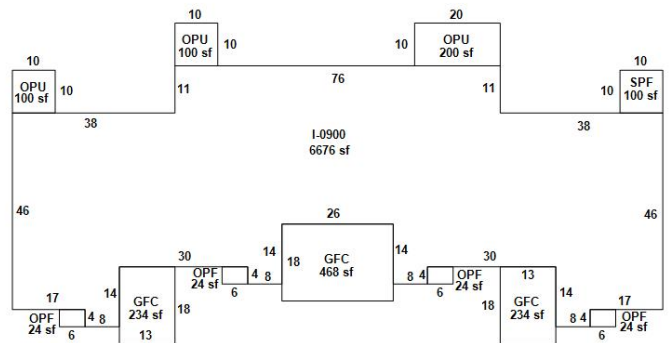

Building 26

Building InformationA	
#	28
Use	MULTIFAMILY
Year Built*	2021
Bed	
Bath	
Fixtures	0
Base Area (ft ²)	3688
Total Area (ft ²)	
Constuction	CONCRETE BLOCK-STUCCO - MASONRY
Replacement Cost	\$580,259
Assessed	\$571,555

* Year Built = Actual / Effective

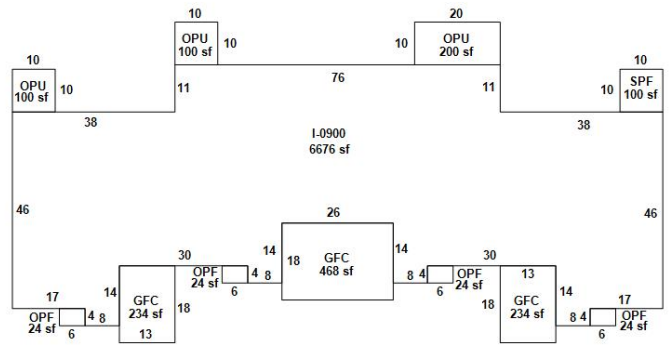

Building 28

AppendagesA	
Description	Area (ft ²)
ENCLOSED PORCH FINISHED	261
GARAGE FINISHED C.B.S.	529
GARAGE FINISHED C.B.S.	529
OPEN PORCH FINISHED	104
OPEN PORCH FINISHED	105
OPEN PORCH FINISHED	350

Building InformationA	
#	29
Use	MULTIFAMILY
Year Built*	2022
Bed	
Bath	
Fixtures	0
Base Area (ft ²)	3688
Total Area (ft ²)	
Constuction	CONCRETE BLOCK-STUCCO - MASONRY
Replacement Cost	\$581,835
Assessed	\$576,017

* Year Built = Actual / Effective

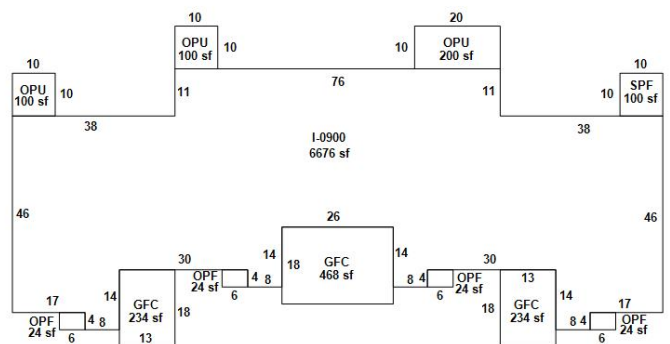

Building 29

Building InformationA	
#	31
Use	MULTIFAMILY
Year Built*	2022
Bed	
Bath	
Fixtures	0
Base Area (ft ²)	3688
Total Area (ft ²)	
Constuction	CONCRETE BLOCK-STUCCO - MASONRY
Replacement Cost	\$583,148
Assessed	\$577,317

* Year Built = Actual / Effective

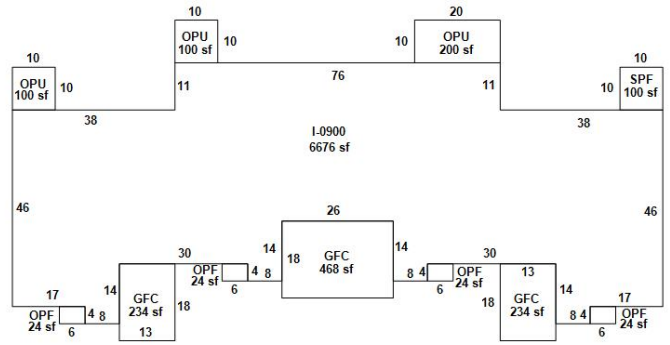

Building 31

AppendagesA	
Description	Area (ft ²)
ENCLOSED PORCH FINISHED	350
GARAGE FINISHED C.B.S.	529
GARAGE FINISHED C.B.S.	529
OPEN PORCH FINISHED	104
OPEN PORCH FINISHED	105
SCREEN PORCH FINISHED	261

Building InformationA	
#	32
Use	MULTIFAMILY
Year Built*	2022
Bed	
Bath	
Fixtures	0
Base Area (ft ²)	3688
Total Area (ft ²)	
Constuction	CONCRETE BLOCK-STUCCO - MASONRY
Replacement Cost	\$576,953
Assessed	\$571,183

* Year Built = Actual / Effective

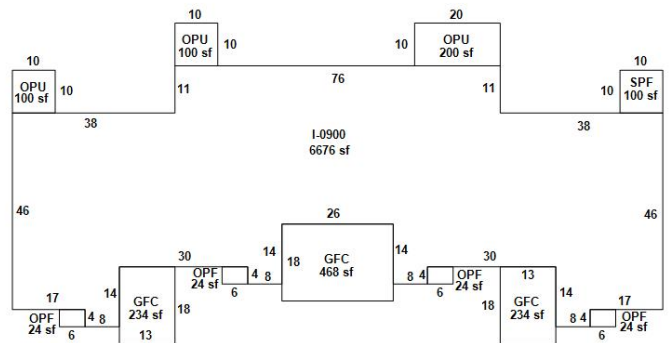

Building 32

AppendagesA

Description	Area (ft²)
GARAGE FINISHED C.B.S.	529
GARAGE FINISHED C.B.S.	529
OPEN PORCH FINISHED	104
OPEN PORCH FINISHED	105
OPEN PORCH FINISHED	350
SCREEN PORCH FINISHED	261

PermitsA

Permit #	Description	Value	CO Date	Permit Date
17028	470 VILLAGE PL: WINDOW / DOOR REPLACEMENT-ALF Window Replacement [VILLAGE ON THE GREEN LONG]	\$9,128		12/5/2024
17604	470 VILLAGE PL: WINDOW / DOOR REPLACEMENT-ALF Window Replacement [VILLAGE ON THE GREEN LONG]	\$14,982		12/5/2024
17027	470 VILLAGE PL: WINDOW / DOOR REPLACEMENT-ALF Window Replacement [VILLAGE ON THE GREEN LONG]	\$7,241		12/5/2024
17608	470 VILLAGE PL: WINDOW / DOOR REPLACEMENT-ALF Window Replacement [VILLAGE ON THE GREEN LONG]	\$9,997		12/5/2024
17033	470 VILLAGE PL: WINDOW / DOOR REPLACEMENT-ALF Window Replacement [VILLAGE ON THE GREEN LONG]	\$13,406		12/5/2024
17607	470 VILLAGE PL: WINDOW / DOOR REPLACEMENT-ALF Window Replacement [VILLAGE ON THE GREEN LONG]	\$8,109		12/5/2024
17019	470 VILLAGE PL: WINDOW / DOOR REPLACEMENT-ALF Window Replacement [VILLAGE ON THE GREEN LONG]	\$10,637		12/5/2024
17602	470 VILLAGE PL: WINDOW / DOOR REPLACEMENT-ALF Window Replacement [VILLAGE ON THE GREEN LONG]	\$15,207		12/5/2024
17022	470 VILLAGE PL: WINDOW / DOOR REPLACEMENT-ALF Window Replacement [VILLAGE ON THE GREEN LONG]	\$7,241		12/3/2024
17025	470 VILLAGE PL: WINDOW / DOOR REPLACEMENT-ALF Window Replacement [VILLAGE ON THE GREEN LONG]	\$13,406		12/3/2024
17029	470 VILLAGE PL: WINDOW / DOOR REPLACEMENT-ALF Window Replacement [VILLAGE ON THE GREEN LONG]	\$10,410		12/3/2024
17036	470 VILLAGE PL: WINDOW / DOOR REPLACEMENT-Window replacement ALF CC [VILLAGE ON THE GREEN LONG]	\$13,664		12/2/2024
17032	470 VILLAGE PL: WINDOW / DOOR REPLACEMENT-Window replacement ALF CC [VILLAGE ON THE GREEN LONG]	\$7,241		12/2/2024

17034	470 VILLAGE PL: WINDOW / DOOR REPLACEMENT-Window replacement ALF CC [VILLAGE ON THE GREEN LONG]	\$9,128	11/27/2024
17023	470 VILLAGE PL: WINDOW / DOOR REPLACEMENT-Window replacement ALF CC [VILLAGE ON THE GREEN LONG]	\$10,410	11/27/2024
17035	470 VILLAGE PL: WINDOW / DOOR REPLACEMENT-Window replacement ALF CC [VILLAGE ON THE GREEN LONG]	\$7,241	11/27/2024
17117	540 VILLAGE PL: ALTERATION COMMERCIAL-55+ apartment building [VILLAGE ON THE GREEN LONG]	\$62,400	11/26/2024
16573	500 VILLAGE PL: FENCE/WALL COMMERCIAL-Fence [VILLAGE ON THE GREEN LONG]	\$14,815	11/26/2024
16786	470 VILLAGE PL: WINDOW / DOOR REPLACEMENT-R2 window replacement [VILLAGE ON THE GREEN LONG]	\$9,128	11/25/2024
16783	470 VILLAGE PL: WINDOW / DOOR REPLACEMENT-ALF Window Replacement [VILLAGE ON THE GREEN LONG]	\$10,410	11/25/2024
16788	470 VILLAGE PL: WINDOW / DOOR REPLACEMENT-ALF window replacement [VILLAGE ON THE GREEN LONG]	\$13,664	11/25/2024
16785	470 VILLAGE PL: WINDOW / DOOR REPLACEMENT-ALF Window Replacement [VILLAGE ON THE GREEN LONG]	\$12,406	11/25/2024
16781	470 VILLAGE PL: WINDOW / DOOR REPLACEMENT-Assisted Living window replacement [VILLAGE ON THE GREEN LONG]	\$7,241	11/25/2024
16780	470 VILLAGE PL: WINDOW / DOOR REPLACEMENT-ALF window replacement [VILLAGE ON THE GREEN LONG]	\$12,406	11/22/2024
16784	470 VILLAGE PL: WINDOW / DOOR REPLACEMENT-Assisted Living window replacement [VILLAGE ON THE GREEN LONG]	\$7,241	11/22/2024
16778	470 VILLAGE PL: WINDOW / DOOR REPLACEMENT-Window replacement ALF CC [VILLAGE ON THE GREEN LONG]	\$7,241	11/21/2024
16777	470 VILLAGE PL: WINDOW / DOOR REPLACEMENT-Window replacement ALF CC [VILLAGE ON THE GREEN LONG]	\$10,637	11/21/2024
17083	430 VILLAGE PL: WINDOW / DOOR REPLACEMENT-55+ apartment building [VILLAGE ON THE GREEN LONG]	\$14,000	11/19/2024
16779	470 VILLAGE PL: WINDOW / DOOR REPLACEMENT- [VILLAGE ON THE GREEN LONG]	\$10,410	11/14/2024
16369	570 VILLAGE PL: ALTERATION COMMERCIAL-55+ apartment building [VILLAGE ON THE GREEN LONG]	\$99,000	11/8/2024
13034	540 VILLAGE PL: WINDOW / DOOR REPLACEMENT- [VILLAGE ON THE GREEN LONG]	\$8,109	11/4/2024
13043	540 VILLAGE PL: WINDOW / DOOR REPLACEMENT- [VILLAGE ON THE GREEN LONG]	\$17,410	11/4/2024

13035	540 VILLAGE PL: WINDOW / DOOR REPLACEMENT- [VILLAGE ON THE GREEN LONG]	\$9,997	11/4/2024
13047	540 VILLAGE PL: WINDOW / DOOR REPLACEMENT- [VILLAGE ON THE GREEN LONG]	\$15,207	11/4/2024
13040	540 VILLAGE PL: WINDOW / DOOR REPLACEMENT- [VILLAGE ON THE GREEN LONG]	\$14,982	11/4/2024
13033	540 VILLAGE PL: WINDOW / DOOR REPLACEMENT- [VILLAGE ON THE GREEN LONG]	\$17,003	11/4/2024
16088	515 VILLAGE PL: ALTERATION COMMERCIAL-Health Care Center [VILLAGE ON THE GREEN LONG]	\$500	10/31/2024
15466	470 VILLAGE PL: ALTERATION COMMERCIAL-55+ apartment building [VILLAGE ON THE GREEN LONG]	\$96,300	10/29/2024
13045	540 VILLAGE PL: WINDOW / DOOR REPLACEMENT- [VILLAGE ON THE GREEN LONG]	\$8,109	10/1/2024
10493	540 VILLAGE PL: WINDOW / DOOR REPLACEMENT- [VILLAGE ON THE GREEN LONG]	\$7,241	10/1/2024
10484	540 VILLAGE PL: WINDOW / DOOR REPLACEMENT- [VILLAGE ON THE GREEN LONG]	\$10,410	10/1/2024
10495	540 VILLAGE PL: WINDOW / DOOR REPLACEMENT- [VILLAGE ON THE GREEN LONG]	\$13,406	10/1/2024
13041	540 VILLAGE PL: WINDOW / DOOR REPLACEMENT- [VILLAGE ON THE GREEN LONG]	\$9,997	10/1/2024
10499	540 VILLAGE PL: WINDOW / DOOR REPLACEMENT- [VILLAGE ON THE GREEN LONG]	\$13,664	9/27/2024
10480	540 VILLAGE PL: WINDOW / DOOR REPLACEMENT- [VILLAGE ON THE GREEN LONG]	\$10,637	9/25/2024
10490	540 VILLAGE PL: WINDOW / DOOR REPLACEMENT- [VILLAGE ON THE GREEN LONG]	\$9,128	9/25/2024
14327	470 VILLAGE PL: ALTERATION COMMERCIAL-55+ apartment building [VILLAGE ON THE GREEN LONG]	\$15,000	9/24/2024
10483	540 VILLAGE PL: WINDOW / DOOR REPLACEMENT- [VILLAGE ON THE GREEN LONG]	\$7,241	9/23/2024
13628	430 VILLAGE PL: ALTERATION COMMERCIAL-55+ apartment building [VILLAGE ON THE GREEN LONG]	\$60,000	9/20/2024
13624	570 VILLAGE PL: ALTERATION COMMERCIAL-ext door like for like [VILLAGE ON THE GREEN LONG]	\$20,400	9/19/2024
12695	590 VILLAGE PL: WINDOW / DOOR REPLACEMENT- [VILLAGE ON THE GREEN LONG]	\$8,632	9/12/2024

12698	540 VILLAGE PL: WINDOW / DOOR REPLACEMENT- [VILLAGE ON THE GREEN LONG]	\$8,632	9/9/2024
12950	515 VILLAGE PL: GAS - COMMERCIAL [VILLAGE ON THE GREEN LONG]	\$0	8/30/2024
10498	540 VILLAGE PL: WINDOW / DOOR REPLACEMENT- [VILLAGE ON THE GREEN LONG]	\$7,241	8/30/2024
12697	570 VILLAGE PL: WINDOW / DOOR REPLACEMENT- [VILLAGE ON THE GREEN LONG]	\$8,632	8/22/2024
10497	540 VILLAGE PL: WINDOW / DOOR REPLACEMENT- [VILLAGE ON THE GREEN LONG]	\$9,128	8/22/2024
12310	540 VILLAGE PL: ALTERATION COMMERCIAL-55+ apartment building [VILLAGE ON THE GREEN LONG]	\$90,000	8/20/2024
12249	470 VILLAGE PL: ALTERATION COMMERCIAL-55+ apartment building [VILLAGE ON THE GREEN LONG]	\$98,000	8/20/2024
10595	570 VILLAGE PL: ALTERATION COMMERCIAL-55+ apartment building [VILLAGE ON THE GREEN LONG]	\$99,400	7/26/2024
10596	590 VILLAGE PL: ALTERATION COMMERCIAL-55+ apartment building CC [VILLAGE ON THE GREEN LONG]	\$20,400	7/23/2024
09582	450 VILLAGE PL: ALTERATION COMMERCIAL-55+ apartment building [VILLAGE ON THE GREEN LONG]	\$24,000	7/8/2024
09646	450 VILLAGE PL: ALTERATION COMMERCIAL-55+ apartment building [VILLAGE ON THE GREEN LONG]	\$96,000	7/1/2024
09839	500 VILLAGE PL: MECHANICAL - COMMERCIAL- [VILLAGE ON THE GREEN LONG]	\$2,500	7/1/2024
07609	461 VILLAGE PL: SCREEN ROOM-Screen Room [VILLAGE ON THE GREEN LONG]	\$19,999	6/24/2024
07660	540 VILLAGE PL: WINDOW / DOOR REPLACEMENT- [VILLAGE ON THE GREEN LONG]	\$9,128	6/18/2024
07618	540 VILLAGE PL: WINDOW / DOOR REPLACEMENT- [VILLAGE ON THE GREEN LONG]	\$12,406	6/17/2024
07662	540 VILLAGE PL: WINDOW / DOOR REPLACEMENT- [VILLAGE ON THE GREEN LONG]	\$13,664	6/17/2024
07617	540 VILLAGE PL: WINDOW / DOOR REPLACEMENT- [VILLAGE ON THE GREEN LONG]	\$10,410	6/17/2024
07621	540 VILLAGE PL: WINDOW / DOOR REPLACEMENT- [VILLAGE ON THE GREEN LONG]	\$9,128	6/17/2024
07988	470 VILLAGE PL: ALTERATION COMMERCIAL-55+ apartment building [VILLAGE ON THE GREEN LONG]	\$450	6/4/2024
07917	590 VILLAGE PL: ALTERATION COMMERCIAL-55+ apartment building [VILLAGE ON THE GREEN LONG]	\$100,000	6/4/2024

07623	540 VILLAGE PL: WINDOW / DOOR REPLACEMENT- [VILLAGE ON THE GREEN LONG]	\$10,410	6/3/2024
07611	540 VILLAGE PL: WINDOW / DOOR REPLACEMENT- [VILLAGE ON THE GREEN LONG]	\$10,637	5/31/2024
07613	540 VILLAGE PL: WINDOW / DOOR REPLACEMENT- [VILLAGE ON THE GREEN LONG]	\$7,241	5/31/2024
07625	540 VILLAGE PL: WINDOW / DOOR REPLACEMENT- [VILLAGE ON THE GREEN LONG]	\$13,406	5/31/2024
05297	500 VILLAGE PL: SITE LIGHTING-VILLAGE ON THE GREEN POST LIGHTS [VILLAGE ON THE GREEN LONG]	\$10,000	5/31/2024
07301	555 VILLAGE PL: REROOF COMMERCIAL- Retirement Complex [VILLAGE ON THE GREEN LONG]	\$64,204	5/29/2024
07206	470 VILLAGE PL: ALTERATION COMMERCIAL-55+ apartment building [VILLAGE ON THE GREEN LONG]	\$67,000	5/22/2024
07205	540 VILLAGE PL: ALTERATION COMMERCIAL-55+ apartment building [VILLAGE ON THE GREEN LONG]	\$75,000	5/22/2024
07106	450 VILLAGE PL: ALTERATION COMMERCIAL-55+ apartment building [VILLAGE ON THE GREEN LONG]	\$0	5/15/2024
07101	515 VILLAGE PL: ALTERATION COMMERCIAL-Health Care Center repair to firewall [VILLAGE ON THE GREEN LONG]	\$700	5/15/2024
07104	590 VILLAGE PL: ALTERATION COMMERCIAL-55+ apartment building [VILLAGE ON THE GREEN LONG]	\$250	5/15/2024
04814	570 VILLAGE PL: WINDOW / DOOR REPLACEMENT- [VILLAGE ON THE GREEN LONG]	\$7,241	4/29/2024
04865	570 VILLAGE PL: WINDOW / DOOR REPLACEMENT- [VILLAGE ON THE GREEN LONG]	\$13,406	4/29/2024
04859	570 VILLAGE PL: WINDOW / DOOR REPLACEMENT- [VILLAGE ON THE GREEN LONG]	\$13,664	4/29/2024
04871	570 VILLAGE PL: WINDOW / DOOR REPLACEMENT- [VILLAGE ON THE GREEN LONG]	\$12,406	4/29/2024
04805	570 VILLAGE PL: WINDOW / DOOR REPLACEMENT- [VILLAGE ON THE GREEN LONG]	\$9,997	4/29/2024
04825	570 VILLAGE PL: WINDOW / DOOR REPLACEMENT- [VILLAGE ON THE GREEN LONG]	\$10,637	4/29/2024
04819	570 VILLAGE PL: WINDOW / DOOR REPLACEMENT- [VILLAGE ON THE GREEN LONG]	\$9,128	4/29/2024
04818	570 VILLAGE PL: WINDOW / DOOR REPLACEMENT- [VILLAGE ON THE GREEN LONG]	\$10,410	4/29/2024

04811	570 VILLAGE PL: WINDOW / DOOR REPLACEMENT- [VILLAGE ON THE GREEN LONG]	\$15,208	4/29/2024
04806	570 VILLAGE PL: WINDOW / DOOR REPLACEMENT- [VILLAGE ON THE GREEN LONG]	\$8,109	4/29/2024
04802	570 VILLAGE PL: WINDOW / DOOR REPLACEMENT- [VILLAGE ON THE GREEN LONG]	\$14,982	4/29/2024
04795	570 VILLAGE PL: WINDOW / DOOR REPLACEMENT- [VILLAGE ON THE GREEN LONG]	\$17,003	4/29/2024
06058	515 VILLAGE PL: ELECTRICAL - COMMERCIAL-MEMORY CARE GARDEN [VILLAGE ON THE GREEN LONG]	\$1,500	4/29/2024
04798	570 VILLAGE PL: WINDOW / DOOR REPLACEMENT- [VILLAGE ON THE GREEN LONG]	\$18,106	4/29/2024
04867	570 VILLAGE PL: WINDOW / DOOR REPLACEMENT- [VILLAGE ON THE GREEN LONG]	\$10,410	4/26/2024
04877	570 VILLAGE PL: WINDOW / DOOR REPLACEMENT- [VILLAGE ON THE GREEN LONG]	\$10,637	4/26/2024
04808	570 VILLAGE PL: WINDOW / DOOR REPLACEMENT- [VILLAGE ON THE GREEN LONG]	\$14,982	4/26/2024
04799	570 VILLAGE PL: WINDOW / DOOR REPLACEMENT- [VILLAGE ON THE GREEN LONG]	\$17,410	4/26/2024
04816	570 VILLAGE PL: WINDOW / DOOR REPLACEMENT- [VILLAGE ON THE GREEN LONG]	\$13,406	4/26/2024
04866	570 VILLAGE PL: WINDOW / DOOR REPLACEMENT- [VILLAGE ON THE GREEN LONG]	\$7,241	4/26/2024
04868	570 VILLAGE PL: WINDOW / DOOR REPLACEMENT- [VILLAGE ON THE GREEN LONG]	\$9,128	4/24/2024
04860	570 VILLAGE PL: WINDOW / DOOR REPLACEMENT- [VILLAGE ON THE GREEN LONG]	\$7,241	4/24/2024
04812	570 VILLAGE PL: WINDOW / DOOR REPLACEMENT- [VILLAGE ON THE GREEN LONG]	\$13,664	4/24/2024
04801	570 VILLAGE PL: WINDOW / DOOR REPLACEMENT- [VILLAGE ON THE GREEN LONG]	\$8,109	4/24/2024
05225	570 VILLAGE PL: ALTERATION COMMERCIAL-55+ apartment building [VILLAGE ON THE GREEN LONG]	\$69,057	4/18/2024
05223	430 VILLAGE PL: ALTERATION COMMERCIAL-55+ apartment building [VILLAGE ON THE GREEN LONG]	\$77,225	4/18/2024
05224	570 VILLAGE PL: ALTERATION COMMERCIAL-55+ apartment building [VILLAGE ON THE GREEN LONG]	\$49,690	4/18/2024

05241	590 VILLAGE PL: ELECTRICAL - COMMERCIAL-BOLLARD LIGHTS BLDG A [VILLAGE ON THE GREEN LONG]	\$2,500	4/11/2024
04567	470 VILLAGE PL: ELECTRICAL - COMMERCIAL- [VILLAGE ON THE GREEN LONG]	\$10,000	4/10/2024
05236	500 VILLAGE PL: ELECTRICAL - COMMERCIAL-BOLLARD LIGHTS [VILLAGE ON THE GREEN LONG]	\$2,500	4/10/2024
03414	549 VILLAGE PL: ALTERATION COMMERCIAL-Pergola on Existing Concrete [VILLAGE ON THE GREEN LONG]	\$7,950	4/3/2024
03541	561 VILLAGE PL: ALTERATION COMMERCIAL-townhome remodel [VILLAGE ON THE GREEN LONG]	\$106,000	3/19/2024
02475	590 VILLAGE PL: WINDOW / DOOR REPLACEMENT- [VILLAGE ON THE GREEN LONG]	\$17,410	3/7/2024
02492	590 VILLAGE PL: WINDOW / DOOR REPLACEMENT- [VILLAGE ON THE GREEN LONG]	\$15,208	3/5/2024
02473	590 VILLAGE PL: WINDOW / DOOR REPLACEMENT- [VILLAGE ON THE GREEN LONG]	\$9,997	3/5/2024
02485	590 VILLAGE PL: WINDOW / DOOR REPLACEMENT- [VILLAGE ON THE GREEN LONG]	\$17,410	3/5/2024
02491	590 VILLAGE PL: WINDOW / DOOR REPLACEMENT- [VILLAGE ON THE GREEN LONG]	\$8,109	3/4/2024
02470	590 VILLAGE PL: WINDOW / DOOR REPLACEMENT- [VILLAGE ON THE GREEN LONG]	\$17,003	3/4/2024
02477	590 VILLAGE PL: WINDOW / DOOR REPLACEMENT- [VILLAGE ON THE GREEN LONG]	\$14,982	3/1/2024
02478	590 VILLAGE PL: WINDOW / DOOR REPLACEMENT- [VILLAGE ON THE GREEN LONG]	\$9,997	3/1/2024
02471	590 VILLAGE PL: WINDOW / DOOR REPLACEMENT- [VILLAGE ON THE GREEN LONG]	\$8,109	3/1/2024
02078	590 VILLAGE PL: WINDOW / DOOR REPLACEMENT- [VILLAGE ON THE GREEN LONG]	\$7,240	2/22/2024
02081	590 VILLAGE PL: WINDOW / DOOR REPLACEMENT- [VILLAGE ON THE GREEN LONG]	\$7,241	2/22/2024
02076	590 VILLAGE PL: WINDOW / DOOR REPLACEMENT- [VILLAGE ON THE GREEN LONG]	\$10,410	2/22/2024
02304	430 VILLAGE PL: ALTERATION COMMERCIAL-55+ apartment building [VILLAGE ON THE GREEN LONG]	\$12,000	2/22/2024
02074	590 VILLAGE PL: WINDOW / DOOR REPLACEMENT- [VILLAGE ON THE GREEN LONG]	\$7,241	2/21/2024

02085	590 VILLAGE PL: WINDOW / DOOR REPLACEMENT- [VILLAGE ON THE GREEN LONG]	\$13,664	2/21/2024
02054	590 VILLAGE PL: WINDOW / DOOR REPLACEMENT- [VILLAGE ON THE GREEN LONG]	\$10,637	2/21/2024
02083	590 VILLAGE PL: WINDOW / DOOR REPLACEMENT- [VILLAGE ON THE GREEN LONG]	\$9,128	2/21/2024
02080	590 VILLAGE PL: WINDOW / DOOR REPLACEMENT- [VILLAGE ON THE GREEN LONG]	\$10,410	2/21/2024
02084	590 VILLAGE PL: WINDOW / DOOR REPLACEMENT- [VILLAGE ON THE GREEN LONG]	\$7,240	2/21/2024
02077	590 VILLAGE PL: WINDOW / DOOR REPLACEMENT- [VILLAGE ON THE GREEN LONG]	\$12,406	2/21/2024
02082	590 VILLAGE PL: WINDOW / DOOR REPLACEMENT- [VILLAGE ON THE GREEN LONG]	\$13,406	2/21/2024
02064	590 VILLAGE PL: WINDOW / DOOR REPLACEMENT- [VILLAGE ON THE GREEN LONG]	\$12,406	2/20/2024
02060	590 VILLAGE PL: WINDOW / DOOR REPLACEMENT- [VILLAGE ON THE GREEN LONG]	\$7,241	2/19/2024
02071	590 VILLAGE PL: WINDOW / DOOR REPLACEMENT- [VILLAGE ON THE GREEN LONG]	\$9,128	2/19/2024
02070	590 VILLAGE PL: WINDOW / DOOR REPLACEMENT- [VILLAGE ON THE GREEN LONG]	\$13,406	2/19/2024
02073	590 VILLAGE PL: WINDOW / DOOR REPLACEMENT- [VILLAGE ON THE GREEN LONG]	\$13,664	2/19/2024
02065	590 VILLAGE PL: WINDOW / DOOR REPLACEMENT- [VILLAGE ON THE GREEN LONG]	\$7,241	2/16/2024
02165	590 VILLAGE PL: WINDOW / DOOR REPLACEMENT- [VILLAGE ON THE GREEN LONG]	\$10,637	2/16/2024
02061	590 VILLAGE PL: WINDOW / DOOR REPLACEMENT- [VILLAGE ON THE GREEN LONG]	\$10,410	2/16/2024
01191	590 VILLAGE PL: ALTERATION COMMERCIAL-55+ apartment building [VILLAGE ON THE GREEN LONG]	\$96,200	2/9/2024
01192	470 VILLAGE PL: ALTERATION COMMERCIAL-55+ apartment building [VILLAGE ON THE GREEN LONG]	\$68,800	2/7/2024
01193	470 VILLAGE PL: ALTERATION COMMERCIAL-55+ apartment building [VILLAGE ON THE GREEN LONG]	\$86,300	2/6/2024
01194	470 VILLAGE PL: ALTERATION COMMERCIAL-55+ apartment building [VILLAGE ON THE GREEN LONG]	\$84,900	2/6/2024

17267	469 VILLAGE PL: ALTERATION COMMERCIAL-CAT3 Sunroom [VILLAGE ON THE GREEN LONG]	\$23,500	2/16/2024	1/23/2024
19283	590 VILLAGE PL: WINDOW / DOOR REPLACEMENT-3 story concrete and brick structure [VILLAGE ON THE GREEN LONG]	\$7,240		1/4/2024
16274	134 GREENTRAIL CT: GAS - COMMERCIAL - [VILLAGE ON THE GREEN LONG]	\$0		11/6/2023
15319	545 VILLAGE PL: RES ALTERATIONS, NO CHANGE IN UNITS-townhome remodel [VILLAGE ON THE GREEN LONG]	\$104,600		10/11/2023
15317	540 VILLAGE PL: ALTERATION COMMERCIAL-55+ apartment building [VILLAGE ON THE GREEN LONG]	\$95,100		10/9/2023
15318	470 VILLAGE PL: ALTERATION COMMERCIAL-55+ apartment building [VILLAGE ON THE GREEN LONG]	\$93,000		10/3/2023
13573	470 VILLAGE PL: ALTERATION COMMERCIAL-55+ apartment building CC [VILLAGE ON THE GREEN LONG]	\$69,000		9/1/2023
13550	590 VILLAGE PL: ALTERATION COMMERCIAL-55+ apartment building [VILLAGE ON THE GREEN LONG]	\$70,000		8/31/2023
13574	590 VILLAGE PL: ALTERATION COMMERCIAL-55+ apartment building [VILLAGE ON THE GREEN LONG]	\$94,000		8/31/2023
12757	465 VILLAGE PL: ALTERATION COMMERCIAL-townhome remodel [VILLAGE ON THE GREEN LONG]	\$106,000		8/16/2023
11220	570 VILLAGE PL: ALTERATION COMMERCIAL-55+ apartment building [VILLAGE ON THE GREEN LONG]	\$94,200		7/26/2023
11458	430 VILLAGE PL: ALTERATION COMMERCIAL-55+ apartment building [VILLAGE ON THE GREEN LONG]	\$77,000		7/26/2023
11459	470 VILLAGE PL: ALTERATION COMMERCIAL-55+ apartment building CC [VILLAGE ON THE GREEN LONG]	\$94,900		7/26/2023
11222	470 VILLAGE PL: ALTERATION COMMERCIAL-55+ apartment building [VILLAGE ON THE GREEN LONG]	\$94,800		7/26/2023
11221	540 VILLAGE PL: ALTERATION COMMERCIAL-55+ apartment building [VILLAGE ON THE GREEN LONG]	\$95,000		7/24/2023
10845	570 VILLAGE PL: ALTERATION COMMERCIAL-55+ apartment building [VILLAGE ON THE GREEN LONG]	\$69,889		7/19/2023
10846	450 VILLAGE PL: ALTERATION COMMERCIAL-55+ apartment building [VILLAGE ON THE GREEN LONG]	\$69,900		7/19/2023
10844	590 VILLAGE PL: ALTERATION COMMERCIAL-55+ apartment building [VILLAGE ON THE GREEN LONG]	\$70,080		7/19/2023
06454	500 VILLAGE PL: SOLAR-POOL/WTR HTR SPLY-pool solar panels on the roof [VILLAGE ON THE GREEN LONG]	\$54,000		5/8/2023

06346	450 VILLAGE PL: ALTERATION COMMERCIAL-55+ apartment building [VILLAGE ON THE GREEN LONG]	\$94,200		5/2/2023
06345	430 VILLAGE PL: ALTERATION COMMERCIAL-55+ apartment building [VILLAGE ON THE GREEN LONG]	\$99,400		5/2/2023
06612	500 VILLAGE PL: ELECTRICAL - COMMERCIAL-Senior Living [VILLAGE ON THE GREEN LONG]	\$2,400		4/28/2023
06347	450 VILLAGE PL: ALTERATION COMMERCIAL-55+ apartment building [VILLAGE ON THE GREEN LONG]	\$94,000		4/28/2023
06344	450 VILLAGE PL: ALTERATION COMMERCIAL-55+ apartment building [VILLAGE ON THE GREEN LONG]	\$95,000		4/27/2023
06265	430 VILLAGE PL: ALTERATION COMMERCIAL-55+ apartment building [VILLAGE ON THE GREEN LONG]	\$94,000		4/25/2023
06264	430 VILLAGE PL: ALTERATION COMMERCIAL-55+ apartment building [VILLAGE ON THE GREEN LONG]	\$95,000		4/25/2023
05610	450 VILLAGE PL: ALTERATION COMMERCIAL-55+ apartment building [VILLAGE ON THE GREEN LONG]	\$69,800		4/24/2023
05609	570 VILLAGE PL: ALTERATION COMMERCIAL-55+ apartment building [VILLAGE ON THE GREEN LONG]	\$69,800		4/20/2023
05611	430 VILLAGE PL: ALTERATION COMMERCIAL-55+ apartment building [VILLAGE ON THE GREEN LONG]	\$71,400		4/20/2023
05908	570 VILLAGE PL: ALTERATION COMMERCIAL-55+ apartment building [VILLAGE ON THE GREEN LONG]	\$77,000		4/20/2023
06176	500 VILLAGE PL: ELECTRICAL - COMMERCIAL-main structure [VILLAGE ON THE GREEN LONG]	\$18,320		4/20/2023
05844	146 GREENTRAIL CT: SCREEN ROOM- CAT3 Sunroom [VILLAGE ON THE GREEN LONG]	\$22,200	7/11/2023	4/18/2023
03485	450 VILLAGE PL: ALTERATION COMMERCIAL-ALTERATION, UNIT 116 [VILLAGE ON THE GREEN LONG]	\$45,560		3/21/2023
03486	450 VILLAGE PL: ALTERATION COMMERCIAL-55+ apartment building [VILLAGE ON THE GREEN LONG]	\$105,100		3/21/2023
02454	450 VILLAGE PL: ALTERATION COMMERCIAL- [VILLAGE ON THE GREEN LONG]	\$4,000		3/15/2023
02644	590 VILLAGE PL: ALTERATION COMMERCIAL-55+ apartment building [VILLAGE ON THE GREEN LONG]	\$94,000		3/1/2023
02647	540 VILLAGE PL: ALTERATION COMMERCIAL-55+ apartment building [VILLAGE ON THE GREEN LONG]	\$94,900		3/1/2023
02635	570 VILLAGE PL: ALTERATION COMMERCIAL-55+ apartment building [VILLAGE ON THE GREEN LONG]	\$68,670		2/28/2023

02610	590 VILLAGE PL: ALTERATION COMMERCIAL-55+ apartment building [VILLAGE ON THE GREEN LONG]	\$69,400		2/28/2023
02649	470 VILLAGE PL: ALTERATION COMMERCIAL-55+ apartment building [VILLAGE ON THE GREEN LONG]	\$94,600		2/28/2023
02646	450 VILLAGE PL: ALTERATION COMMERCIAL-55+ apartment building [VILLAGE ON THE GREEN LONG]	\$91,000		2/24/2023
02641	590 VILLAGE PL: ALTERATION COMMERCIAL-55+ apartment building [VILLAGE ON THE GREEN LONG]	\$77,940		2/24/2023
02638	540 VILLAGE PL: ALTERATION COMMERCIAL-55+ apartment building [VILLAGE ON THE GREEN LONG]	\$69,884		2/23/2023
02640	470 VILLAGE PL: ALTERATION COMMERCIAL-55+ apartment building [VILLAGE ON THE GREEN LONG]	\$70,462		2/22/2023
02067	450 VILLAGE PL: ALTERATION COMMERCIAL-55+ apartment building [VILLAGE ON THE GREEN LONG]	\$92,800		2/22/2023
01444	515 VILLAGE PL: ELECTRICAL - COMMERCIAL-none [VILLAGE ON THE GREEN LONG]	\$3,500		2/22/2023
02636	570 VILLAGE PL: ALTERATION COMMERCIAL-55+ apartment building [VILLAGE ON THE GREEN LONG]	\$70,170		2/22/2023
01466	182 GREENTRAIL CT: POOL ENCLOSURE/BOND-SCREEN ENCLOSURE on EXISTING FOUNDATION [VILLAGE ON THE GREEN LONG]	\$4,800	4/21/2023	2/10/2023
01445	430 VILLAGE PL: ELECTRICAL - COMMERCIAL-irrigation well [VILLAGE ON THE GREEN LONG]	\$3,500		2/7/2023
00706	430 VILLAGE PL: ALTERATION COMMERCIAL-55+ apartment building [VILLAGE ON THE GREEN LONG] (renovation of bathroom only in unit F-102)	\$69,980		2/2/2023
20392	430 VILLAGE PL: ALTERATION COMMERCIAL-55+ apartment building	\$90,000		12/19/2022
20374	570 VILLAGE PL: ALTERATION COMMERCIAL-55+ apartment building	\$80,000		12/9/2022
20373	590 VILLAGE PL: ALTERATION COMMERCIAL-55+ apartment building	\$73,000		12/9/2022
20372	450 VILLAGE PL: ALTERATION COMMERCIAL-55+ apartment building	\$89,193		12/9/2022
18708	147 GREENTRAIL CT: RES ADDITION TO EXISTING STRUCTURE-VILLA 147 (1/4/2022 PERMITTING SAYS IT IS CURRENTLY ON HOLD) ENCLOSING PORCH	\$22,337	7/28/2023	12/8/2022
16881	134 GREENTRAIL CT: RES ADDITION TO EXISTING STRUCTURE-Villa 134	\$70,000	6/26/2024	12/2/2022
18441	540 VILLAGE PL: ALTERATION COMMERCIAL-55+ apartment building	\$61,329		11/16/2022
18442	590 VILLAGE PL: ALTERATION COMMERCIAL-55+ apartment building	\$62,495		11/8/2022

18438	470 VILLAGE PL: ALTERATION COMMERCIAL-55+ apartment building	\$60,661		11/8/2022
18446	549 VILLAGE PL: ALTERATION COMMERCIAL-condo interior alterations	\$102,766		11/8/2022
17567	570 VILLAGE PL: ALTERATION COMMERCIAL-55+ apartment building	\$47,450		11/1/2022
16049	450 VILLAGE PL: ALTERATION COMMERCIAL-apartment building CC	\$72,000		10/20/2022
16944	540 VILLAGE PL: ALTERATION COMMERCIAL-apartment building level 2 alt	\$92,000		10/20/2022
16882	146 GREENTRAIL CT: RES ALTERATIONS, NO CHANGE IN UNITS-Villa 146	\$45,000	1/18/2023	10/19/2022
16047	401 MOSSY STONE CT: RES ALTERATIONS NO CHANGE IN UNITS-Interior alterations	\$90,000		10/10/2022
14144	450 VILLAGE PL: ALTERATION COMMERCIAL-Condo Need CC	\$88,465		9/15/2022
14544	417 THE CIRCLE : SCREEN ROOM- SCREEN ROOM with electric [THE COVE]	\$16,688		9/12/2022
12366	182 GREENTRAIL CT: RES ADDITION TO EXISTING STRUCTURE-ADDITION & INTERIOR FINISH. ALL PERMITS FINALS APPROVED IN OCTOBER 2022 WITH EXCEPTION OF THE FINAL. (BUILDING PLACED ON TAX ROLL) .LEF	\$67,000	1/26/2023	8/17/2022
11208	430 VILLAGE PL: ALTERATION COMMERCIAL-apartment building	\$78,000		8/11/2022
12588	150 GREENTRAIL CT: ALTERATION COMMERCIAL-install kitchen island	\$45,000	11/15/2022	8/4/2022
12155	469 VILLAGE PL: ALTERATION COMMERCIAL-townhome remodel	\$90,000		8/2/2022
09727	417 THE CIRCLE : ALTERATION COMMERCIAL-townhome remodel [THE COVE]	\$100,000		7/14/2022
05494	147 GREENTRAIL CT: RES ALTERATIONS, NO CHANGE IN UNITS-Villa 147	\$47,000	7/15/2022	6/10/2022
05552	590 VILLAGE PL: ALTERATION COMMERCIAL-Condo	\$49,500		6/9/2022
07190	590 VILLAGE PL: ALTERATION COMMERCIAL-Retirement community	\$21,369		6/9/2022
05493	138 GREENTRAIL CT: RES ADDITION TO EXISTING STRUCTURE-Villa 138	\$67,000	9/8/2022	6/1/2022
07194	430 VILLAGE PL: ALTERATION COMMERCIAL-Residential Townhomes	\$73,204		5/26/2022
04954	540 VILLAGE PL: ALTERATION COMMERCIAL-Carport C and Clubhouse Walkway	\$5,000	7/18/2022	5/26/2022
04955	470 VILLAGE PL: ALTERATION COMMERCIAL-Carport D	\$20,000	7/26/2022	5/26/2022
04956	450 VILLAGE PL: ALTERATION COMMERCIAL-Carport E	\$12,000	7/26/2022	5/26/2022
04957	430 VILLAGE PL: ALTERATION COMMERCIAL-Carport F	\$8,000	8/11/2022	5/26/2022
19656	500 VILLAGE PL: ALTERATION COMMERCIAL-NEED CC Screen Room	\$2,600,000	8/8/2023	5/20/2022
04952	590 VILLAGE PL: ALTERATION COMMERCIAL-Carport	\$28,000	7/26/2022	5/13/2022
04953	570 VILLAGE PL: ALTERATION COMMERCIAL-Carport B	\$6,000	7/18/2022	5/12/2022

07374	515 VILLAGE PL: WINDOW / DOOR REPLACEMENT-VOTG Health Center [VILLAGE ON THE GREEN LONG]	\$7,500	8/11/2022	5/12/2022
05553	570 VILLAGE PL: ALTERATION COMMERCIAL-Condo CC IF REQUESTED	\$49,500		5/6/2022
05817	529 VILLAGE PL: ALTERATION COMMERCIAL-Residential Townhomes CC IF REQUESTED	\$66,597		5/2/2022
05807	470 VILLAGE PL: ALTERATION COMMERCIAL-Residential Townhomes CC IF REQUESTED	\$52,613		4/28/2022
04210	430 VILLAGE PL: ALTERATION COMMERCIAL-Residential Townhomes	\$82,135		4/18/2022
04189	540 VILLAGE PL: ALTERATION COMMERCIAL-Residential Townhomes	\$61,234		4/14/2022
03182	590 VILLAGE PL: ALTERATION COMMERCIAL-apartment unit	\$71,000	6/6/2022	3/29/2022
03181	570 VILLAGE PL: ALTERATION COMMERCIAL-apartment unit	\$90,000	10/28/2022	3/29/2022
03184	570 VILLAGE PL: ALTERATION COMMERCIAL-Apartment unit	\$85,000		3/29/2022
01448	470 VILLAGE PL: ALTERATION COMMERCIAL-Condominium	\$50,513	6/3/2022	2/22/2022
22715	170 GREENTRAIL CT: RES ALTERATIONS, NO CHANGE IN UNITS-Build 7 - Villa 170	\$47,000	10/5/2022	2/3/2022
22803	151 GREENTRAIL CT: RES ALTERATIONS, NO CHANGE IN UNITS-COMPLETION OF BATH, KITCHEN, LAUNDRY	\$45,000	4/28/2022	12/20/2021
16483	541 VILLAGE PL: RES ALTERATIONS, NO CHANGE IN UNITS-Villa [VILLAGE ON THE GREEN LONG]	\$55,000	4/21/2022	10/12/2021
16281	570 VILLAGE PL: ALTERATION COMMERCIAL-apartment unit [VILLAGE ON THE GREEN LONG]	\$45,000	3/2/2022	10/12/2021
16278	430 VILLAGE PL: ALTERATION COMMERCIAL-apartment unit [VILLAGE ON THE GREEN LONG]	\$45,000	11/16/2021	9/17/2021
16280	430 VILLAGE PL: ALTERATION COMMERCIAL-apartment unit [VILLAGE ON THE GREEN LONG]	\$40,000	11/16/2021	9/17/2021
13286	196 GREENTRAIL CT: RES ADDITION TO EXISTING STRUCTURE-ALTERATION ENCLOSURE, COMPLETE PLB & CAB [VILLAGE ON THE GREEN LONG]	\$67,000	12/7/2021	8/24/2021
11676	590 VILLAGE PL: ALTERATION COMMERCIAL-apartment unit REMODEL CC [VILLAGE ON THE GREEN LONG]	\$43,500	12/8/2021	7/26/2021
11652	540 VILLAGE PL: ALTERATION COMMERCIAL-Apartment REMODEL [VILLAGE ON THE GREEN LONG]	\$58,000	12/2/2021	7/8/2021
08699	186 GREENTRAIL CT: RES ADDITION TO EXISTING STRUCTURE-Villa 9 - Unit 186 [VILLAGE ON THE GREEN LONG]	\$45,000	8/3/2021	6/14/2021
09977	415 THE CIRCLE : WINDOW / DOOR REPLACEMENT-Villa 415 [VILLAGE ON THE GREEN LONG]	\$6,000	10/28/2021	6/3/2021

05321	430 VILLAGE PL: ALTERATION COMMERCIAL-INT ALT CC NO CO [VILLAGE ON THE GREEN LONG]	\$59,000	5/26/2021	5/6/2021
04313	200 GREENTRAIL CT: ALTERATION COMMERCIAL-FINISH OUT DUPLEX CO REQ. [VILLAGE ON THE GREEN LONG]	\$45,000	5/3/2021	4/20/2021
04310	163 GREENTRAIL CT: RES ADDITION TO EXISTING STRUCTURE-INTERIOR FINISH/ ADDITION [VILLAGE ON THE GREEN LONG]	\$45,000	6/29/2021	4/13/2021
03535	540 VILLAGE PL: ALTERATION COMMERCIAL-Carport C REPAIR [VILLAGE ON THE GREEN LONG]	\$34,250	2/4/2022	4/2/2021
03317	191 GREENTRAIL CT: RES ALTERATIONS, NO CHANGE IN UNITS-INTERIOR FINISH [VILLAGE ON THE GREEN LONG]	\$45,000	5/17/2021	3/30/2021
03319	195 GREENTRAIL CT: RES ALTERATIONS, NO CHANGE IN UNITS- [VILLAGE ON THE GREEN LONG]	\$47,000	5/21/2021	3/25/2021
20803	450 VILLAGE PL: ALTERATION COMMERCIAL-Commercial Alteration [VILLAGE ON THE GREEN LONG]	\$38,000	2/19/2021	1/19/2021
20004	481 VILLAGE PL: MISC BUILDING - COMMERCIAL-concrete pad [VILLAGE ON THE GREEN LONG]	\$2,400	3/19/2021	12/28/2020
17376	430 VILLAGE PL: ALTERATION COMMERCIAL-INT ALT CC NO CO [VILLAGE ON THE GREEN LONG]	\$59,000	12/2/2021	12/15/2020
18986	418 THE CIRCLE : ALTERATION COMMERCIAL-TERMITE REPAIRS [VILLAGE ON THE GREEN LONG]	\$20,000	3/19/2021	12/15/2020
19309	430 VILLAGE PL: ALTERATION COMMERCIAL-Carports REPAIR [VILLAGE ON THE GREEN LONG]	\$25,000	3/30/2021	12/10/2020
08987	500 VILLAGE PL: ALTERATION COMMERCIAL-PARTIAL DEMO AND REBUILD [VILLAGE ON THE GREEN LONG]	\$175,752	9/10/2021	11/23/2020
13291	450 VILLAGE PL: ALTERATION COMMERCIAL-INT ALT LEVEL 2 [VILLAGE ON THE GREEN LONG]	\$39,000	10/20/2020	9/23/2020
11522	540 VILLAGE PL: ALTERATION COMMERCIAL-Apartment [VILLAGE ON THE GREEN LONG]	\$34,000	9/15/2020	8/19/2020
10382	412 THE CIRCLE : RES ALTERATIONS, NO CHANGE IN UNITS-9 MOTORIZED HURRICANE SHUTTERS [VILLAGE ON THE GREEN LONG]	\$25,000	10/20/2020	7/31/2020
00865	170 GREENTRAIL CT: DUPLEX TWO FAMILY BLDG-Villa 7 - Unit 170 [VILLAGE ON THE GREEN LONG]	\$277,075	12/2/2020	4/3/2020
02260	200 GREENTRAIL CT: DUPLEX TWO FAMILY BLDG-Villa 10 - Unit 200 [VILLAGE ON THE GREEN LONG]	\$266,950	12/2/2020	4/3/2020
00864	163 GREENTRAIL CT: DUPLEX TWO FAMILY BLDG-Villa 6 - Unit 163 [VILLAGE ON THE GREEN LONG]	\$277,075	10/27/2020	3/25/2020
00812	147 GREENTRAIL CT: DUPLEX TWO FAMILY BLDG-Villa 4 - Unit 147 [VILLAGE ON THE GREEN LONG]	\$266,950	10/27/2020	3/25/2020

02258	195 GREENTRAIL CT: DUPLEX TWO FAMILY BLDG-Villa 8 - Unit 195 [VILLAGE ON THE GREEN LONG]	\$277,075	12/2/2020	3/20/2020
00012	450 VILLAGE PL: ALTERATION COMMERCIAL-RENOVATION LEVEL 1 [VILLAGE ON THE GREEN LONG]	\$50,112	9/3/2020	3/10/2020
00111	150 GREENTRAIL CT: DUPLEX TWO FAMILY BLDG-Villa 3 - Unit 150 [VILLAGE ON THE GREEN LONG]	\$266,950	10/29/2020	3/6/2020
00048	146 GREENTRAIL CT: DUPLEX TWO FAMILY BLDG-UNIT B OF DUPLEX Villa 3 - Unit 146 [VILLAGE ON THE GREEN LONG]	\$277,075	10/29/2020	3/6/2020
01457	186 GREENTRAIL CT: DUPLEX TWO FAMILY BLDG-Villa 9 - unit 186 [VILLAGE ON THE GREEN LONG]	\$266,950	12/2/2020	3/4/2020
02108	470 VILLAGE PL: ALTERATION COMMERCIAL-INT ALT [VILLAGE ON THE GREEN LONG]	\$20,000	4/16/2020	3/4/2020
01484	182 GREENTRAIL CT: DUPLEX TWO FAMILY BLDG-Villa 9 - Unit 182 [VILLAGE ON THE GREEN LONG]	\$277,075	12/2/2020	3/4/2020
17841	570 VILLAGE PL: ALTERATION COMMERCIAL-LEVEL 1 ALTERATION [VILLAGE ON THE GREEN LONG]	\$50,112	9/3/2020	3/3/2020
00043	134 GREENTRAIL CT: DUPLEX TWO FAMILY BLDG-Villa 2 - Unit 134 [VILLAGE ON THE GREEN LONG]	\$277,075	9/16/2020	2/26/2020
00109	138 GREENTRAIL CT: DUPLEX TWO FAMILY BLDG-Villa 2 - Unit 138 [VILLAGE ON THE GREEN LONG]	\$266,950	10/8/2020	2/26/2020
01550	450 VILLAGE PL: ALTERATION COMMERCIAL-INT ALT LEVEL 2 [VILLAGE ON THE GREEN LONG]	\$20,000	4/16/2020	2/25/2020
10975	500 VILLAGE PL: ALTERATION COMMERCIAL-LEVEL 2 ALTERATION NEED C.C. [VILLAGE ON THE GREEN LONG]	\$1,736,732	9/10/2021	2/19/2020
16323	126 GREENTRAIL CT: DUPLEX TWO FAMILY BLDG-Villa A Unit [VILLAGE ON THE GREEN LONG]	\$266,950	8/25/2020	2/5/2020
16320	122 GREENTRAIL CT: DUPLEX TWO FAMILY BLDG-Villa B Unit [VILLAGE ON THE GREEN LONG]	\$277,075	8/25/2020	2/5/2020
13762	470 VILLAGE PL: ALTERATION COMMERCIAL-INT ALTERATION [VILLAGE ON THE GREEN LONG]	\$20,000	7/29/2020	12/18/2019
10146	515 VILLAGE PL: HOSPITALS OR INSTITUTIONAL BLDGS-RESIDENTIAL CARE NEED C.O. [VILLAGE ON THE GREEN LONG]	\$23,230,166	2/3/2021	12/17/2019
13764	430 VILLAGE PL: ALTERATION COMMERCIAL-INT ALT NO CO [VILLAGE ON THE GREEN LONG]	\$20,000	1/22/2020	12/3/2019
13535	470 VILLAGE PL: ALTERATION COMMERCIAL-INDEPENDENT LIVING [VILLAGE ON THE GREEN LONG]	\$30,000	1/8/2020	12/2/2019
13631	461 VILLAGE PL: ALTERATION COMMERCIAL-LEVEL 2 ALT [VILLAGE ON THE GREEN LONG]	\$25,000	12/18/2019	11/8/2019

18615 418 THE CIRCLE : ALTERATION
 COMMERCIAL-MINOR INT REMODEL \$43,000 10/6/2021 1/1/1900
 [VILLAGE ON THE GREEN LONG]

Extra FeaturesA

Description	Year Built	Units	Cost	Assessed
POOL COMMERCIAL	1986	2042	\$177,041	\$106,225
WALKS CONC COMM	1986	11814	\$64,268	\$25,707
SCREEN ENCL 1	2023	1	\$4,000	\$3,867
POLE LIGHT 1 ARM	1986	4	\$7,416	\$7,416
POLE LIGHT 1 ARM	1986	4	\$7,416	\$7,416
POLE LIGHT 1 ARM	1986	4	\$7,416	\$7,416
POLE LIGHT 1 ARM	1986	4	\$7,416	\$7,416
POLE LIGHT 1 ARM	1986	4	\$7,416	\$7,416
COMM: ALUM SCREEN PORCH W/CONC FL	1989	120	\$1,680	\$672
COMM: ALUM SCREEN PORCH W/CONC FL	1989	100	\$1,400	\$560
COMM: ALUM SCREEN PORCH W/CONC FL	2008	216	\$3,024	\$1,413
BLOCK WALL	2021	168	\$2,330	\$2,214
WOOD DECK	1996	120	\$828	\$331
COMM: ALUM SCREEN PORCH W/CONC FL	2008	98	\$1,372	\$641
COMM: ALUM SCREEN PORCH W/CONC FL	2006	200	\$2,800	\$1,120
COMM: ALUM SCREEN PORCH W/CONC FL	2006	100	\$1,400	\$560
COMMERCIAL ASPHALT DR 2 IN	1986	180274	\$459,699	\$183,880
SPA 3	1986	1	\$19,440	\$7,776
WALKS CONC COMM	2021	17465	\$95,010	\$87,884
COOL DECK PATIO	1986	5502	\$29,931	\$11,972
COMM: ALUM SCREEN PORCH W/CONC FL	2006	100	\$1,400	\$560
ROOM ENCLOSURE 1	2008	1	\$5,000	\$3,000
COMMERCIAL ASPHALT DR 2 IN	2021	51198	\$130,555	\$120,763
BRICK WALL	1986	5760	\$122,285	\$48,914
ALUM FENCE	2021	94	\$1,410	\$1,304
WALKS CONC COMM	1986	5138	\$27,951	\$11,180
POLE LIGHT 1 ARM	1986	25	\$46,350	\$46,350
POLE LIGHT 1 ARM	2021	33	\$61,182	\$61,182
FACE BLOCK WALL	1986	1820	\$28,046	\$11,218
COMMERCIAL ASPHALT DR 2 IN	1989	23616	\$60,221	\$24,088
BRICK WALL	1986	1977	\$41,972	\$16,789
IRON FENCE	1986	1634	\$25,556	\$10,222
POLE LIGHT 1 ARM	1986	9	\$16,686	\$16,686

ZoningA	
Zoning	PD
Description	Planned Development
Future Land Use	PD
Description	Planned Development

School DistrictsA	
Elementary	Sabal Point
Middle	Rock Lake
High	Lyman

Political RepresentationA	
Commissioner	District 3 - Lee Constantine
US Congress	District 7 - Cory Mills
State House	District 39 - Doug Bankson
State Senate	District 10 - Jason Brodeur
Voting Precinct	Precinct 35

UtilitiesA	
Fire Station #	Station: 16 Zone: 161
Power Company	DUKE
Phone (Analog)	CENTURY LINK
Water	Sunshine Water Services
Sewage	Sunshine Water Services
Garbage Pickup	
Recycle	
Yard Waste	
Hauler #	

Property Value HistoryA

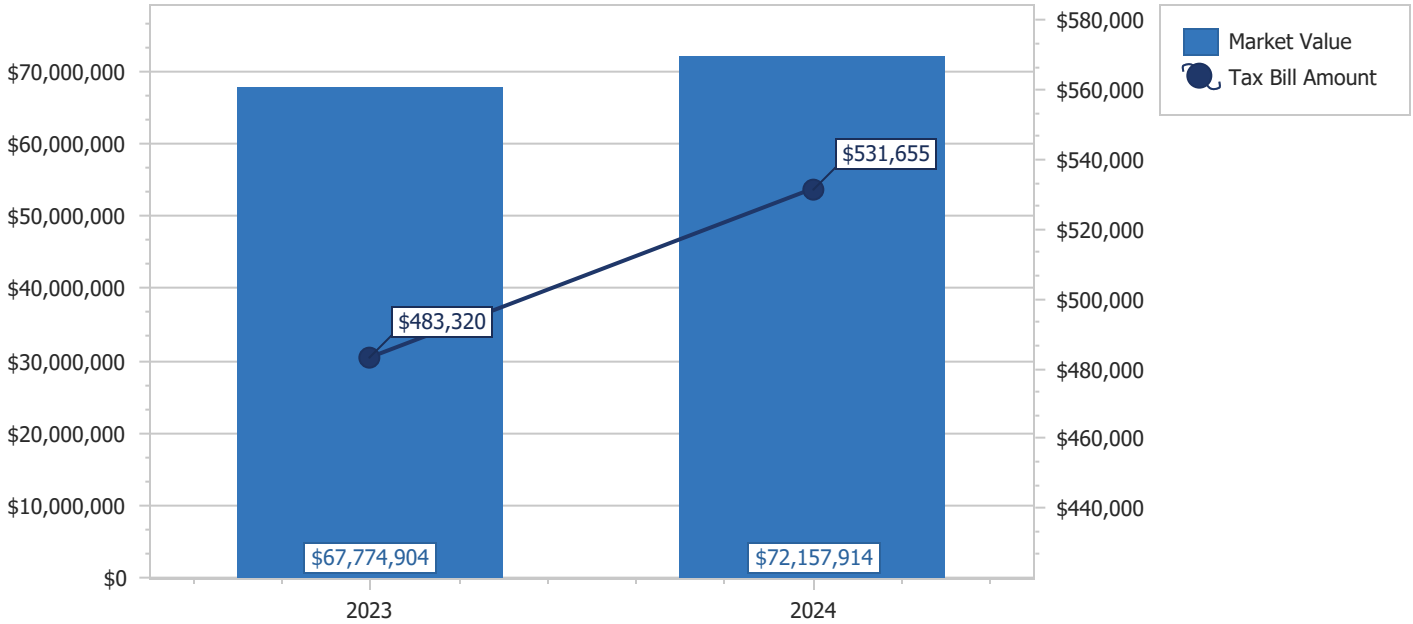

Copyright 2025 © Seminole County Property Appraiser



**Seminole County Government
Development Services Department
Planning and Development Division
Credit Card Payment Receipt**

If you have questions about your application or payment, please email us eplandesk@seminolecountyfl.gov or call us at: (407) 665-7371.

Receipt Details

Date: 12/12/2024 1:25:06 PM
Project: 24-80000139
Credit Card Number: 55*****9586
Authorization Number: 085971
Transaction Number: 121224O2D-BE83E5C9-9B1B-4EDC-9F8C-8F17386A44D0
Total Fees Paid: 52.50

Fees Paid

Description	Amount
CC CONVENIENCE FEE -- PZ	2.50
PRE APPLICATION	50.00
Total Amount	52.50