



SEMINOLE COUNTY
 PLANNING & DEVELOPMENT DIVISION
 1101 EAST FIRST STREET, ROOM 2028
 SANFORD, FLORIDA 32771
 (407) 665-7371 EPLANDESK@SEMINOLECOUNTYFL.GOV

PROJ. #: 24-80000068

Received: 5/17/24

Paid: 5/20/24

PRE-APPLICATION

INCOMPLETE APPLICATIONS WILL NOT BE ACCEPTED

APPLICATION FEE

PRE-APPLICATION \$50.00

PROJECT

PROJECT NAME: Heathrow Pickleball

PARCEL ID #(S): 12-20-29-300-0140-0000

TOTAL ACREAGE: 20.17

BCC DISTRICT: 5

ZONING: PD ~~Commercial~~

FUTURE LAND USE: Planned Development

APPLICANT

NAME: Concert Golf Partners

COMPANY: Concert Golf Partners

ADDRESS: 300 International Parkway, Suite 150

CITY: Lake Mary

STATE: Florida

ZIP: 32746

PHONE:

EMAIL:

CONSULTANT

NAME: Anne Roun

COMPANY: Larson Design Group

ADDRESS: 495 North Keller Road, Suite 101

CITY: Maitland

STATE: Florida

ZIP: 32751

PHONE: (689)710-0035

EMAIL: aroun@larsondesigngroup.com

PROPOSED DEVELOPMENT (CHECK ALL THAT APPLY)

SUBDIVISION LAND USE AMENDMENT REZONE SITE PLAN SPECIAL EXCEPTION

Description of proposed development: Proposing construction of Pickle ball courts in existing open recreation area on site.

STAFF USE ONLY

COMMENTS DUE: 5/31

COM DOC DUE: 6/6

DRC MEETING: 6/12

PROPERTY APPRAISER SHEET PRIOR REVIEWS:

ZONING: PD

FLU: PD

LOCATION:

W/S: Seminole County

BCC: 5: Herr

on the west side of Tournament Dr,
north of Lake Mary Blvd

Agenda: 6/7



Heathrow Pickleball Narrative

05/17/2024

Project location

150 Tournament Drive Lake Mary, Florida 32746

28.759628012928285, -81.3772371894344

Narrative

Proposing construction of 6 Pickle ball courts in existing open recreation area on site. Minor demolishing of existing sidewalk to be replaced with proposed sidewalk. Project will require adjustment in grading. Integrity of drainage routes to be maintained post construction. No utilities adjusted or proposed.

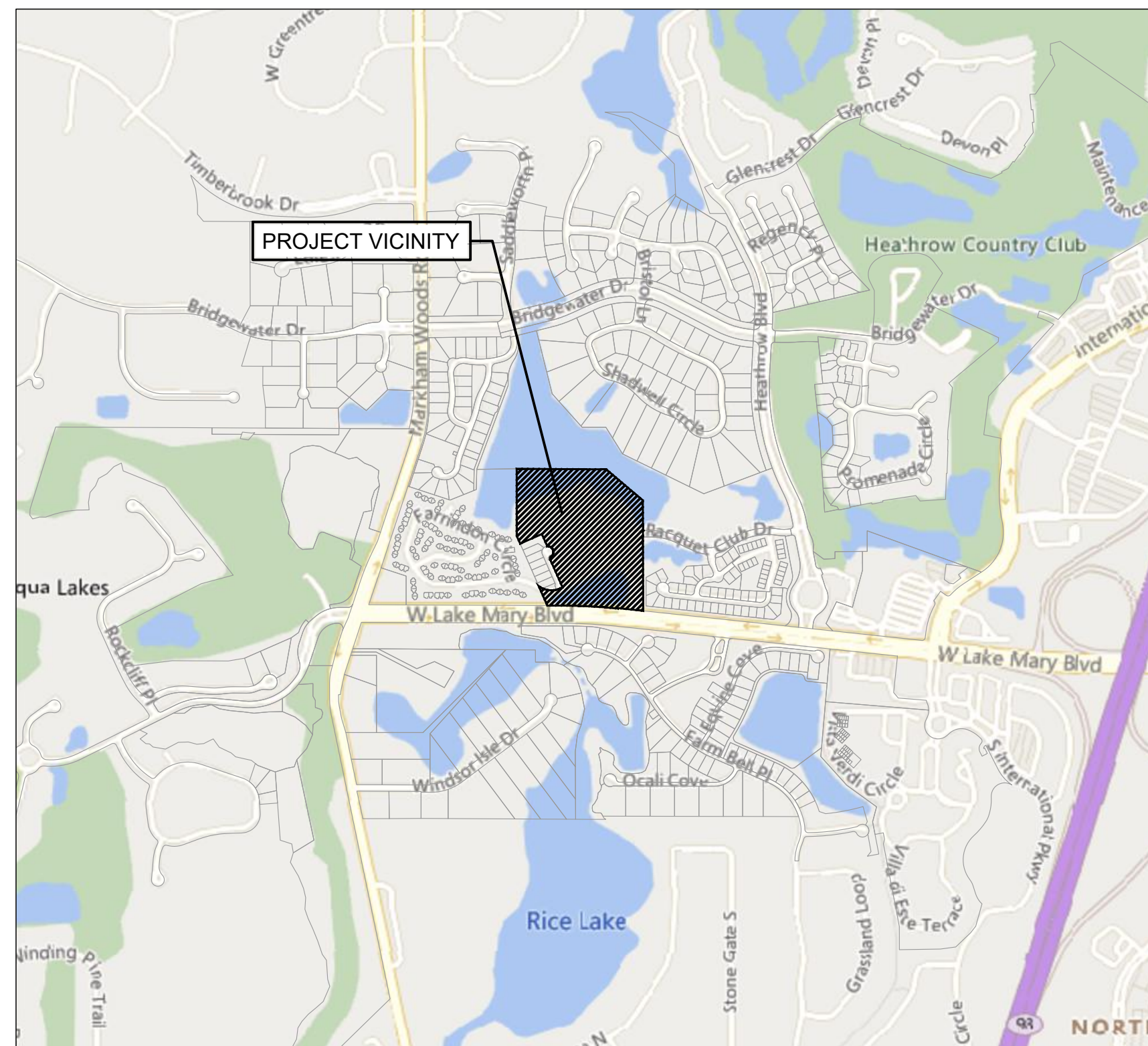
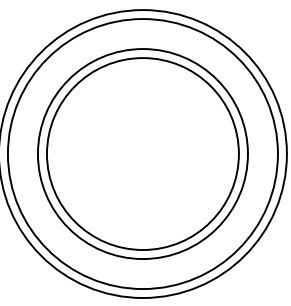

LOCATION / VICINITY MAP

SCALE: 1" = 1000'



SHEET INDEX	
SHEET	TITLE
C0.00	COVER SHEET
C0.01	GENERAL NOTES
C0.02	TOPOGRAPHIC SURVEY
C1.00	DEMO & EROSION CONTROL PLAN
C2.00	SITE LAYOUT PLAN
C3.00	GRADING & DRAINAGE PLAN
C4.00	CONSTRUCTION DETAILS
C4.10	CONSTRUCTION DETAILS
SL-1	SITE LIGHTING PLAN

CONCERT GOLF PARTNERS

300 INTERNATIONAL PARKWAY, SUITE 150

LAKE MARY, FLORIDA 32746

Larson Design Group

CONTRACTOR PRIOR TO SUBMITTAL TO THE OWNER'S ENGINEER.

- 12. WORK PERFORMED UNDER THIS CONTRACT SHALL INTERFACE SMOOTHLY WITH OTHER WORK BEING PERFORMED ON SITE BY OTHER CONTRACTORS AND UTILITY COMPANIES. IT WILL BE NECESSARY FOR THE CONTRACTOR TO COORDINATE AND SCHEDULE HIS ACTIVITIES, WHERE NECESSARY, WITH OTHER CONTRACTORS AND UTILITY COMPANIES.
- 13. ALL WORK SHALL BE PERFORMED IN A SAFE MANNER. ALL SAFETY RULES AND GUIDELINES OF O.S.H.A. SHALL BE FOLLOWED. THE CONTRACTOR SHALL BE WHOLLY RESPONSIBLE FOR ANY INJURIES OF HIS EMPLOYEES, AND ANY DAMAGE TO PRIVATE PROPERTY OR PERSONS DURING THE COURSE OF THIS PROJECT. ALL COSTS ASSOCIATED WITH COMPLYING WITH O.S.H.A. REGULATIONS AND THE FLORIDA TRENCH SAFETY ACT MUST BE INCLUDED IN THE CONTRACTORS BID.
- 14. THE CONTRACTOR SHALL TAKE ALL NECESSARY MEASURES TO PROTECT ALL TREES AND OTHER VEGETATION OUTSIDE THE LIMITS OF CONSTRUCTION.
- 15. THE CONTRACTOR SHALL LOCATE AND FLAG ALL PROPERTY CORNERS PRIOR TO FINAL ENGINEERING INSPECTION AND CERTIFICATION. IT SHALL BE THE CONTRACTOR'S RESPONSIBILITY TO HAVE PROPERTY CORNERS, WHICH HAVE BEEN LOST DURING CONSTRUCTION, RE-ESTABLISHED BY A PROFESSIONAL LAND SURVEYOR.
- 16. THE CONTRACTOR IS ADVISED TO VERIFY AND LOCATE ALL HORIZONTAL AND VERTICAL CONTROL POINTS PRIOR TO CONSTRUCTION, BRING ANY LAYOUT DISCREPANCIES TO THE IMMEDIATE ATTENTION OF THE ENGINEER.
- 17. PRIOR TO CONSTRUCTION, THE CONTRACTOR SHALL CLEARLY DESIGNATE THE LIMITS OF CONSTRUCTION ON SITE. THE CONTRACTOR SHALL NOT PERFORM ANY WORK OUTSIDE THE LIMITS OF CONSTRUCTION.
- 18. IMPROVEMENTS SHOWN ARE TO BE WARRANTED BY THE CONTRACTOR TO THE OWNER/DEVELOPER FOR A PERIOD OF ONE YEAR FROM DATE OF ACCEPTANCE BY THE OWNER/DEVELOPER. IF THE WORK IS IN A RIGHT-OF-WAY OR EASEMENT, THE CONTRACTOR'S ONE YEAR WARRANTY SHALL EXTEND TO THE ENTITY HOLDING THE RIGHT-OF-WAY OR EASEMENT.
- 19. NO EXTRA PAYMENTS SHALL BE ALLOWED FOR ANY WORK REQUIRED DUE TO MISUNDERSTANDING OF JOB OR SITE CONDITIONS AFFECTING THE WORK AS DESCRIBED IN THE SPECIFICATIONS OR SHOWN ON THE DRAWINGS. THE CONTRACTOR SHALL NOT TAKE ADVANTAGE OF ANY APPARENT ERROR OR OMISSION IN THE DRAWINGS OR SPECIFICATIONS, AND THE ENGINEER SHALL BE PERMITTED TO MAKE CORRECTIONS AND INTERPRETATION AS MAY BE DEEMED NECESSARY FOR THE FULFILLMENT OF THE INTENT OF THE CONTRACTS DOCUMENTS. THE TENDERING OF A PROPOSAL WILL ACKNOWLEDGE ACCEPTANCE OF THESE CONDITIONS BY THE BIDDER.
- 20. THE CONTRACTOR WILL CONTRACT WITH AN INDEPENDENT TESTING LABORATORY TO PERFORM ALL MATERIAL AND SOIL TESTING AS REQUIRED BY THE AHJ, THESE CONSTRUCTION PLANS, AND THE SPECIFICATIONS. TESTS SHALL INCLUDE DENSITY TESTS IN ALL PAVEMENT AND BUILDING PAD AREAS, IN ALL UTILITY TRENCHES LOCATED IN PAVEMENT AREAS, CONCRETE TESTING, AND ALL OTHER MATERIAL TESTING. PRIOR TO PAVEMENT BASE PLACEMENT, THE PROJECT GEOTECHNICAL ENGINEER SHALL MAKE RECOMMENDATION FOR UNDERDRAIN PLACEMENT, IF NECESSARY.
- 21. CONTRACTOR SHALL LEAVE THE SITE FREE OF HOLES, HAZARDS, IMPOUNDMENTS, AND DEBRIS UPON COMPLETION.
- 22. NOISE LEVELS AND HOURS OF OPERATION SHOULD COORDINATED WITH OWNER AND PER LOCAL, STATE, AND FEDERAL LAWS.

DEMOLITION NOTES:

- 1. THE CONTRACTOR IS TO PREPARE THE SITE PRIOR TO BEGINNING ACTUAL CONSTRUCTION IN ACCORDANCE WITH THE SOILS TESTING REPORT. CONTRACTOR CAN REQUEST A COPY OF THE SOILS REPORT FROM THE EOR.
- 2. THE CONTRACTOR SHALL IMMEDIATELY NOTIFY THE PROJECT ENGINEER PRIOR TO CONSTRUCTION OF ANY DISCREPANCIES FOUND BETWEEN THESE PLANS AND EXISTING FIELD CONDITIONS.
- 3. PRIOR TO ANY SITE CLEARING, ALL TREES SHOWN TO REMAIN ON THE CONSTRUCTION PLANS SHALL BE PROTECTED IN ACCORDANCE WITH THE LOCAL REGULATORY AGENCY'S TREE ORDINANCE AND DETAILS CONTAINED IN THESE PLANS. IT SHALL BE THE CONTRACTOR'S RESPONSIBILITY TO MAINTAIN THESE TREES IN GOOD CONDITION. NO TREES SHOWN TO REMAIN SHALL BE REMOVED WITHOUT WRITTEN APPROVAL FROM THE OWNER.
- 4. CONTRACTOR SHALL COORDINATE WITH THE OWNER REGARDING LOCATION TO STOCKPILE ANY REUSABLE STRUCTURES, PAVEMENT BASE MATERIAL, FIXTURES, ETC.
- 5. THE CONTRACTOR SHALL CLEAR AND GRUB ONLY THOSE PORTIONS OF THE SITE NECESSARY FOR CONSTRUCTION. DISTURBED AREAS WILL BE SEEDED, MULCHED, OR

EXIST PER EDEP'S CURRENT PUBLISHED DISCHARGE STANDARDS.

PAVING, GRADING AND DRAINAGE NOTES:

- 1. ALL CONSTRUCTION SHALL BE IN ACCORDANCE WITH THE FOLLOWING SPECIFICATIONS:
SEMINOLE COUNTY, FLORIDA
SEMINOLE COUNTY DEPARTMENT OF HEALTH (DOH)
ST. JOHNS RIVER WATER MANAGEMENT DISTRICT (SJRWMD)
FLORIDA DEPARTMENT OF ENVIRONMENTAL PROTECTION (FDEP)
FLORIDA DEPARTMENT OF TRANSPORTATION (FDOT)
US ENVIRONMENTAL PROTECTION AGENCY (EPA)
- 2. PRIOR TO CONSTRUCTION, THE CONTRACTOR SHALL FIELD VERIFY LOCATIONS AND INVERTS OF EXISTING UTILITIES AT PROPOSED CROSSINGS AND POINTS OF CONNECTION. THE CONTRACTOR SHALL NOTIFY THE ENGINEER IMMEDIATELY, IN WRITING, OF ANY UTILITY CONFLICTS OR DISCREPANCIES.
- 3. CONTRACTOR SHALL STAKE ALL IMPROVEMENTS USING THE GEOMETRIC DATA PROVIDED. IT IS THE CONTRACTOR'S SOLE RESPONSIBILITY TO COMPLETELY STAKE AND CHECK ALL IMPROVEMENTS TO ENSURE ADEQUATE POSITIONING, BOTH HORIZONTAL AND VERTICAL, PRIOR TO INSTALLATION OF IMPROVEMENTS. THE CONTRACTOR SHALL NOTIFY THE EOR IMMEDIATELY, IN WRITING, IF ANY APPARENT DISCREPANCIES ARE FOUND.
- 4. CONTRACTOR SHALL REFER TO THE GEOTECHNICAL REPORT FOR ALL SITE PREPARATIONS AND EARTHWORK OPERATIONS AND ADHERE TO THE REQUIREMENTS SET FORTH WITHIN.
- 5. ALL DELETERIOUS SUBSTANCE MATERIAL (E.G. MUCK, PEAT, BURIED DEBRIS) IS TO BE EXCAVATED IN ACCORDANCE WITH THESE PLANS OR AS DIRECTED BY THE OWNER'S ENGINEER OR THE OWNER'S SOIL TESTING COMPANY. DELETERIOUS MATERIAL IS TO BE STOCKPILED OR REMOVED FROM THE SITE AS DIRECTED BY THE OWNER. EXCAVATED AREAS ARE TO BE BACKFILLED WITH APPROVED MATERIALS AND COMPACTED AS SHOWN ON THESE PLANS.
- 6. THE CONTRACTOR SHALL BE RESPONSIBLE FOR PROTECTING EXCAVATIONS AGAINST COLLAPSE AND WILL PROVIDE BRACING, SHEETING OR SHORING AS NECESSARY. TRENCHES SHALL BE KEPT DRY WHILE PIPE AND APPURTENANCES ARE BEING PLACED. DEWATERING SHALL BE USED AS REQUIRED. ALL EXCAVATIONS SHOULD COMPLY WITH LOCAL, STATE, AND FEDERAL REGULATIONS, INCLUDING THE CURRENT OSHA EXCAVATION AND TRENCH SAFETY STANDARDS.
- 7. IT MAY BE NECESSARY TO FIELD ADJUST PAVEMENT ELEVATIONS TO PRESERVE THE ROOT SYSTEMS OF TREES SHOWN TO BE SAVED. THE CONTRACTOR IS TO COORDINATE WITH THE EOR PRIOR TO ANY CHANGES.
- 8. ALL DRAINAGE PIPING SHALL HAVE A MINIMUM OF 3.0 FEET OF COVER MEASURED FROM FINISH GRADES TO OUTSIDE OF PIPE, UNLESS OTHERWISE NOTED. ALL PIPE LENGTHS ARE SCALED DIMENSIONS. ALL DRAINAGE STRUCTURES SHALL BE CONSTRUCTED TO CONFORM TO FDOT STANDARDS AND SPECIFICATIONS. ALL DRAINAGE STRUCTURES WITHIN TRAFFIC AREAS SHALL BE LOAD RATED AND HAVE H-20 BEARING GRATES. DITCH BOTTOM AND CONTROL STRUCTURE INLET GRATES SHALL BE SECURED BY CHAIN AND EYEBOLT.
- 9. ALL STORM WATER PIPE SHALL BE REINFORCED CONCRETE CLASS III (ASTM C-76) OR APPROVED EQUAL UNLESS OTHERWISE NOTED ON PLANS. ALL DRAINAGE PIPE JOINTS SHALL BE WRAPPED IN FILTER FABRIC WRAP PER FDOT STANDARD PLANS INDEX 430-001. PVC STORM PIPE (12" AND SMALLER) SHALL CONFORM TO AWWA C-900, CLASS 150 STANDARDS UNLESS OTHERWISE NOTED.
- 10. THE STORM DRAINAGE PIPING AND FILTRATION SYSTEM SHALL BE SUBJECT TO A VISUAL INSPECTION BY THE OWNER'S ENGINEER PRIOR TO THE PLACEMENT OF BACKFILL. THE CONTRACTOR IS TO NOTIFY THE ENGINEER 48 HOURS IN ADVANCE TO SCHEDULE AN INSPECTION.
- 11. THE CONTRACTOR SHALL MAINTAIN AND PROTECT FROM MUD, DIRT, DEBRIS, ETC. THE STORM DRAINAGE SYSTEM UNTIL FINAL ACCEPTANCE OF THE PROJECT. THE STORM SYSTEM WILL BE REINSPECTED BY THE OWNER'S ENGINEER PRIOR TO APPROVAL OF AS-BUILTS. THE CONTRACTOR MAY BE REQUIRED TO RE-CLEAN PIPES AND INLETS AT THE CONTRACTOR'S EXPENSE AND PRIOR TO FINAL ACCEPTANCE.
- 12. THE CONTRACTOR WILL STABILIZE ANY DISTURBED AREAS BY SEED AND MULCH, SOD, OR OTHER APPROVED MATERIALS IMMEDIATELY FOLLOWING CONSTRUCTION. CONTRACTOR SHALL MAINTAIN THESE AREAS UNTIL FINAL ACCEPTANCE BY OWNER. CONTRACTOR TO COORDINATE WITH OWNER REGARDING TYPE OF MATERIAL, LANDSCAPING, AND IRRIGATION REQUIREMENTS. MAINTENANCE RESPONSIBILITIES INCLUDE MOWING, TEMPORARY IRRIGATION, AND APPLICATION OF FERTILIZER.

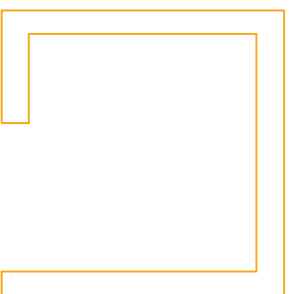

SURVEYOR NOTES

- The last date of field survey was March 06, 2024.
- This survey was prepared in accordance with the "Standards of Practice", as set forth by the Florida Board of Professional Surveyors and Mappers in rule 5J-17.050 through 5J-17.053, of the Florida Administrative Code, pursuant to Chapter 472, Florida Statutes.
- This survey map and/or report, or the copies thereof, is not valid without the signature and the original embossed seal or digital signature of a Florida Licensed Surveyor and Mapper.
- The coordinate system utilized herein is relative to the Florida State Plane Coordinate System, East Zone (0901), North American Datum of 1983 (NAD 83), 2011 realization as derived by Real-Time Kinematic Global Positioning System (RTK GPS) survey methods using the public Florida Department of Transportation's Florida Permanent Reference Network (FPRN); mountpoint base station (SNFD). The corrected positions computed by these networks were verified through redundant measures employing National Geodetic Survey (NGS) On-Line Positioning User Service (OPUS).
- This Specific Purpose Survey is referenced to the Vertical Datum NAVD88 through the same methods as detailed in note #4.
- All distances shown herein are in U.S. survey feet.
- This Specific Purpose Survey is intended for topographic purposes.
- Underground improvements, if any, were not located except as shown. Utility designation services were not subcontracted.
- Symbols shown herein are not to scale.
- Interior improvements, if any, were not located except as shown.
- Adjoining property information was obtained from Seminole County, Florida Property Appraiser.
- There is no visible evidence of cemeteries on subject property.
- This survey is without benefit of a title report and is not to be accepted as a boundary survey.
- The property shown herein may be subject to easements, restrictions, and/or reservations of record and not of record.
- No determination, research, or verification regarding Flood Zone classification was performed by this surveyor.

PARTIAL TOPOGRAPHIC SURVEY

Heathrow Athletic Club proposed Pickleball Court

LOCATED IN

SECTION 11, TOWNSHIP 20 SOUTH, RANGE 29 EAST

HEATHROW, SEMINOLE COUNTY, FLORIDA

FOR THE BENEFIT OF:

Concert Golf Partners

SURVEYOR CERTIFICATION

For the benefit of: Concert Golf Partners
I hereby certify that this Specific Purpose survey is correct to the best of my knowledge and belief. I further certify that this Specific Purpose survey meets the Standards of Practice as set forth by the Florida Board of Professional Surveyors and Mappers in Chapter 5J-17, Florida Administrative Code, pursuant to Chapter 472, Florida Statutes. Subject to notes and notations shown herein.

For the firm:
Larson Design Group

Date: 03/12/2024 Signed:
Tim C. Jaskiewicz, PSM
Professional Surveyor and Mapper
Florida License No. 7416

It is a violation of the law for any person, unless acting under the direction of a licensed Architect, Engineer or Land Surveyor, to alter an item in any way. Plans, maps, specifications, studies, and reports not containing a red ink seal imprint on the cover sheet accompanied by an original signature by the licensed professional may have been fraudulently altered and shall not be considered an original copy. Copyright Protected 2024, Larson Design Group.

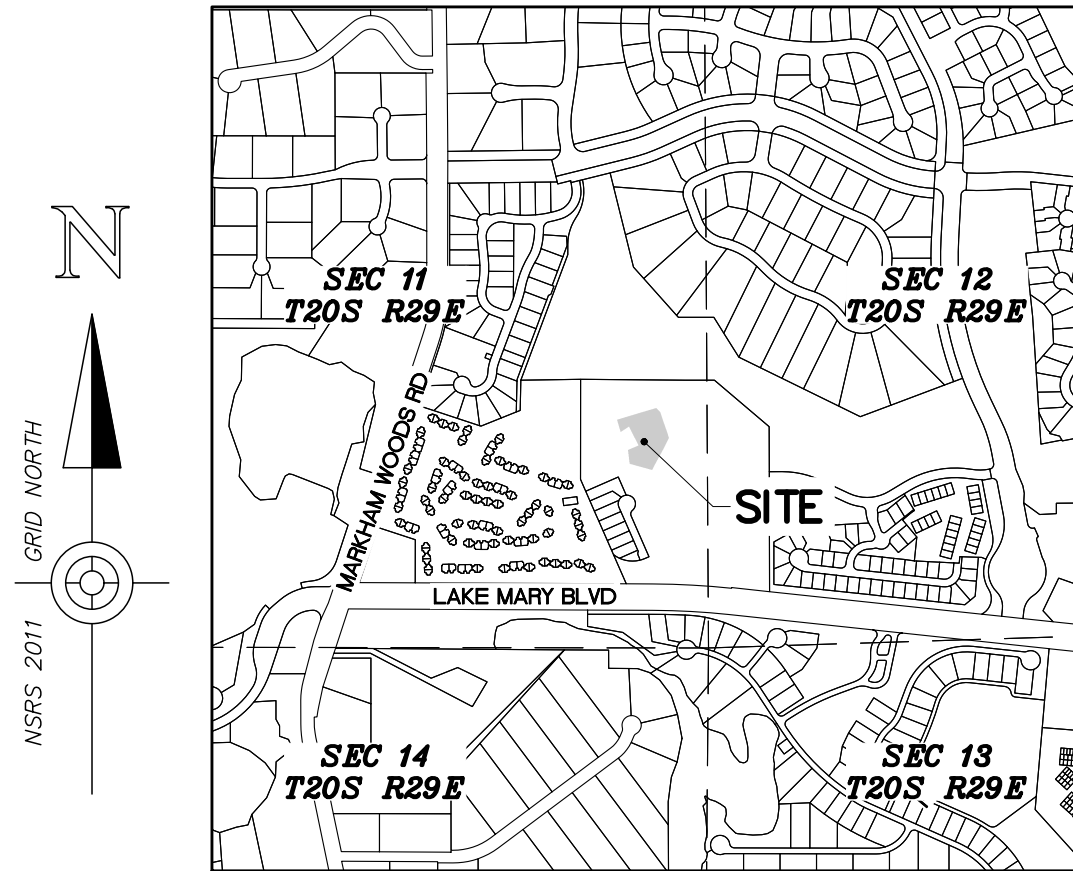

PROJECT LOCATION MAP
Based on public GIS data
(1" = 1000')

LEGEND	
PROPOSED PROPERTY BOUNDARY	---
ADJACENT PROPERTY BOUNDARY	---
RIGHT-OF-WAY LINE	---
EASEMENT LINE	---
CENTER LINE OF ROAD	---
BUILDING SETBACK	---
BUILDING LINE	---
FENCE LINE	---
EDGE OF PAVEMENT	---
EDGE OF GRAVEL/STONE/SPOIL PILE	---
CONCRETE CURB	---
CONCRETE/SIDEWALK	---
BRICK PAVERS	---
BITUMINOUS PAVEMENT	---
BENCHMARK	⊕
IRON ROD/PIN	○
MONUMENT	□
DECIDUOUS TREE	○
PINE TREE	△
PALM TREE	✶
DITCH/SWALE	---
DRAINAGE LINE, MANHOLE & CB	---
SANITARY SEWER & MANHOLE	---
WATER MAIN, VALVE, & METER	---
SEWER FORCE MAIN	---
GAS MAIN & VALVE	---
UNDERGROUND ELECTRIC	---
UNDERGROUND CABLE TV	---
OVERHEAD UTILITIES, GUY, & POLE	---
UNDERGROUND TELEPHONE	---
BEARING/DISTANCE PER THIS SURVEY	S10° 11' 12"W 345.67'
RECORD BEARING/DISTANCE	(S9° 10' 11"W) (346.54')
CLF CHAIN-LINK FENCE	MH MANHOLE
CM CONCRETE MONUMENT	PVC POLYVINYL CHLORATE PIPE
CMP CORRUGATED METAL PIPE	RCP REINFORCED CONCRETE PIPE
(D) PER DEED	R.O.W. RIGHT-OF-WAY
FFE FINISHED FLOOR ELEVATION	(S) AS SURVEYED
FH FIRE HYDRANT	SAN SANITARY SEWER
IRC IRON ROD WITH CAP	SCO SEWER CLEANOUT
(M) AS MEASURED	SV SEWER VALVE
MES MITERED END SECTION	WV WATER VALVE

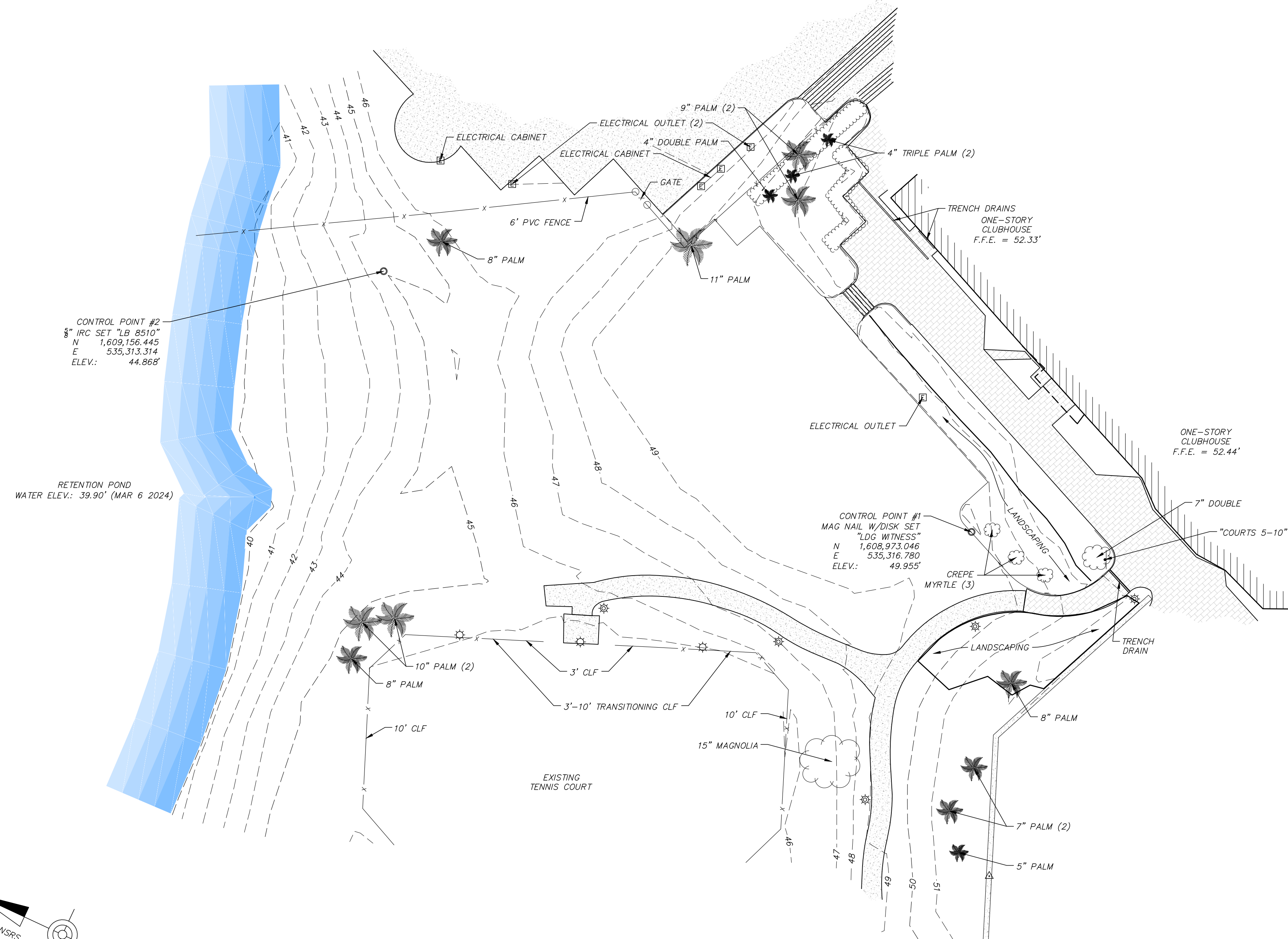
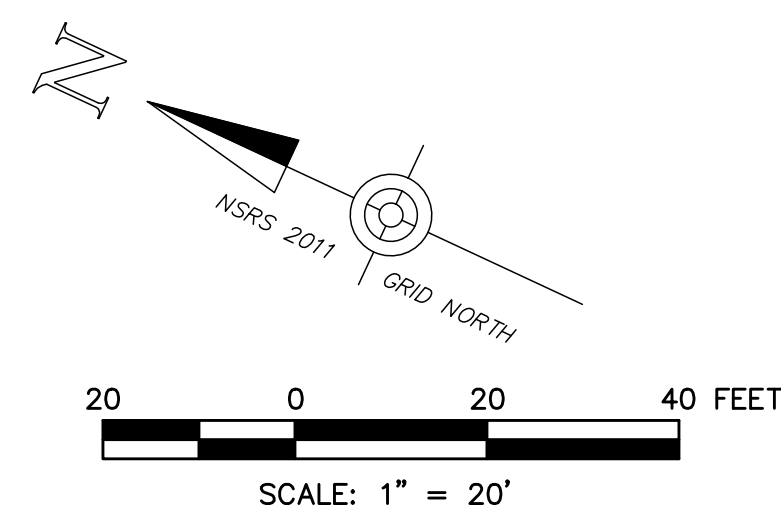

NO.	DATE	ISSUE / REVISIONS
03/11/24	JSP	TCL
	JSP	CHKD



Partial Topographic Survey
Heathrow Athletic Club
Proposed Pickleball Court Area
Heathrow, Seminole County, Florida

Larson Design Group • Architects Engineers Surveyors
495 N Keller Road • Suite 101
Maitland, FL 32751
PHONE 689.229.2485 TOLL FREE 877.323.6603
LB No. 8510 • www.larsondesigngroup.com

CONCERT GOLF PARTNERS
300 International Parkway Suite 150
Lake Mary, Florida 32746
PHONE 949.715.0602

SHEET NO.:
C0.02

PROJECT NO.: 13671-001

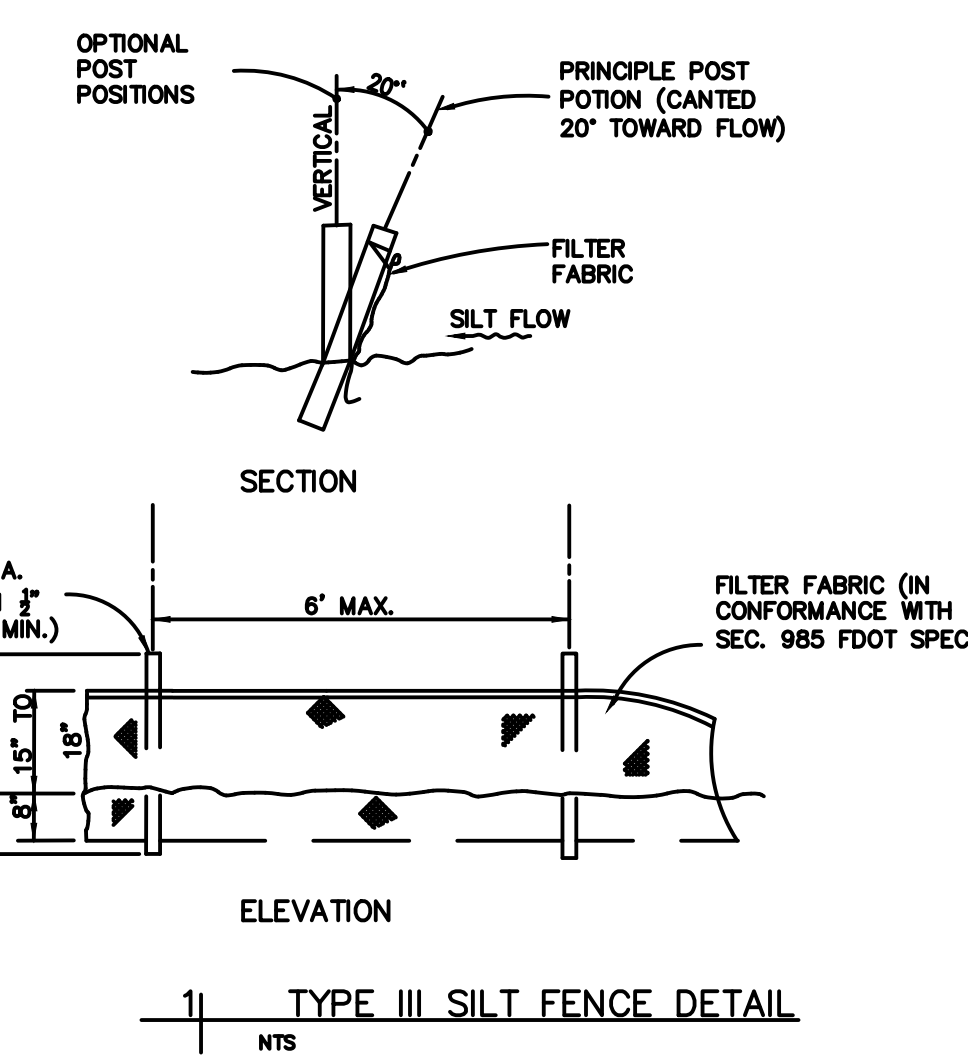
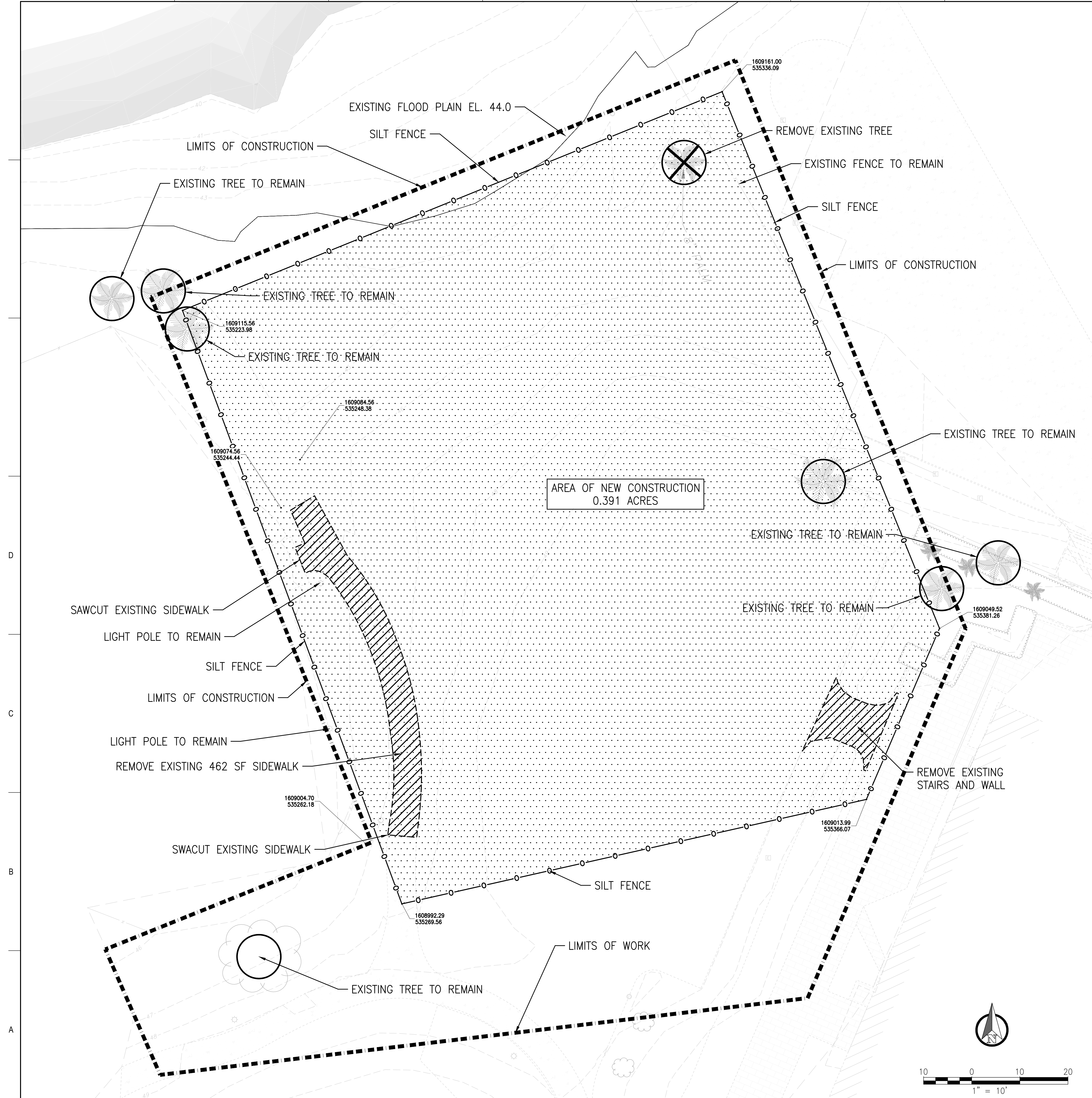
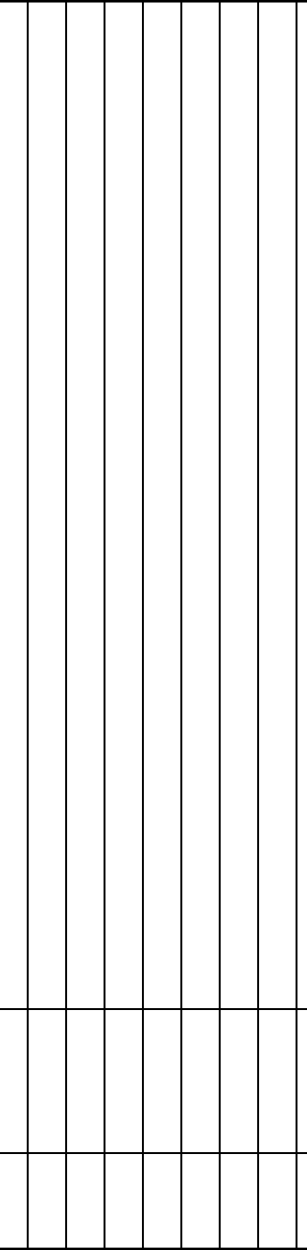
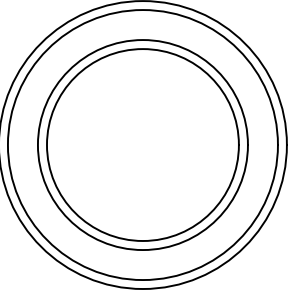

—		

▨		
~~~~~		
-o-o-		
+		
⊗		
○		

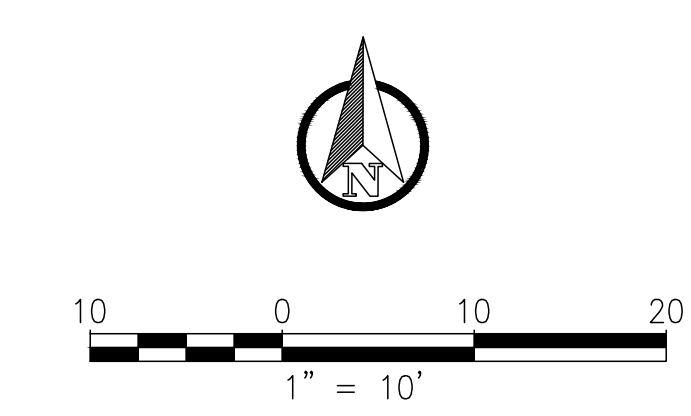



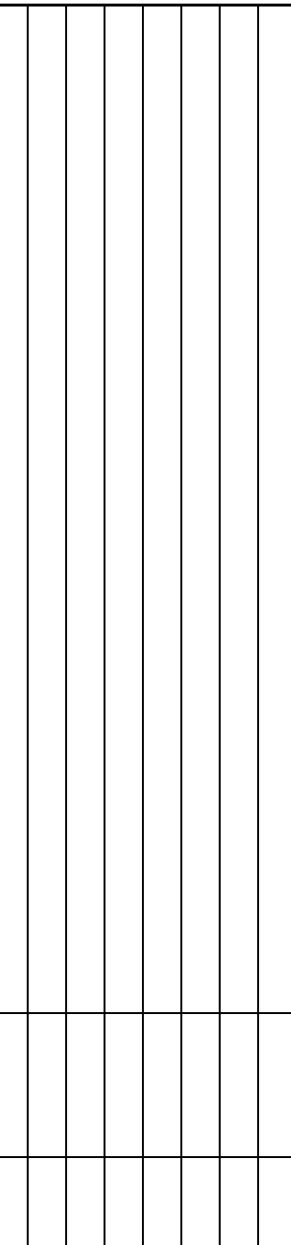
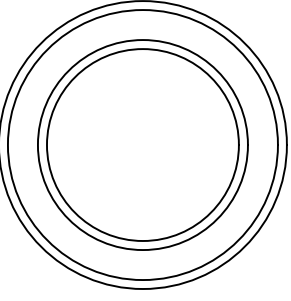

STORMWATER POLLUTION & PREVENTION PLAN

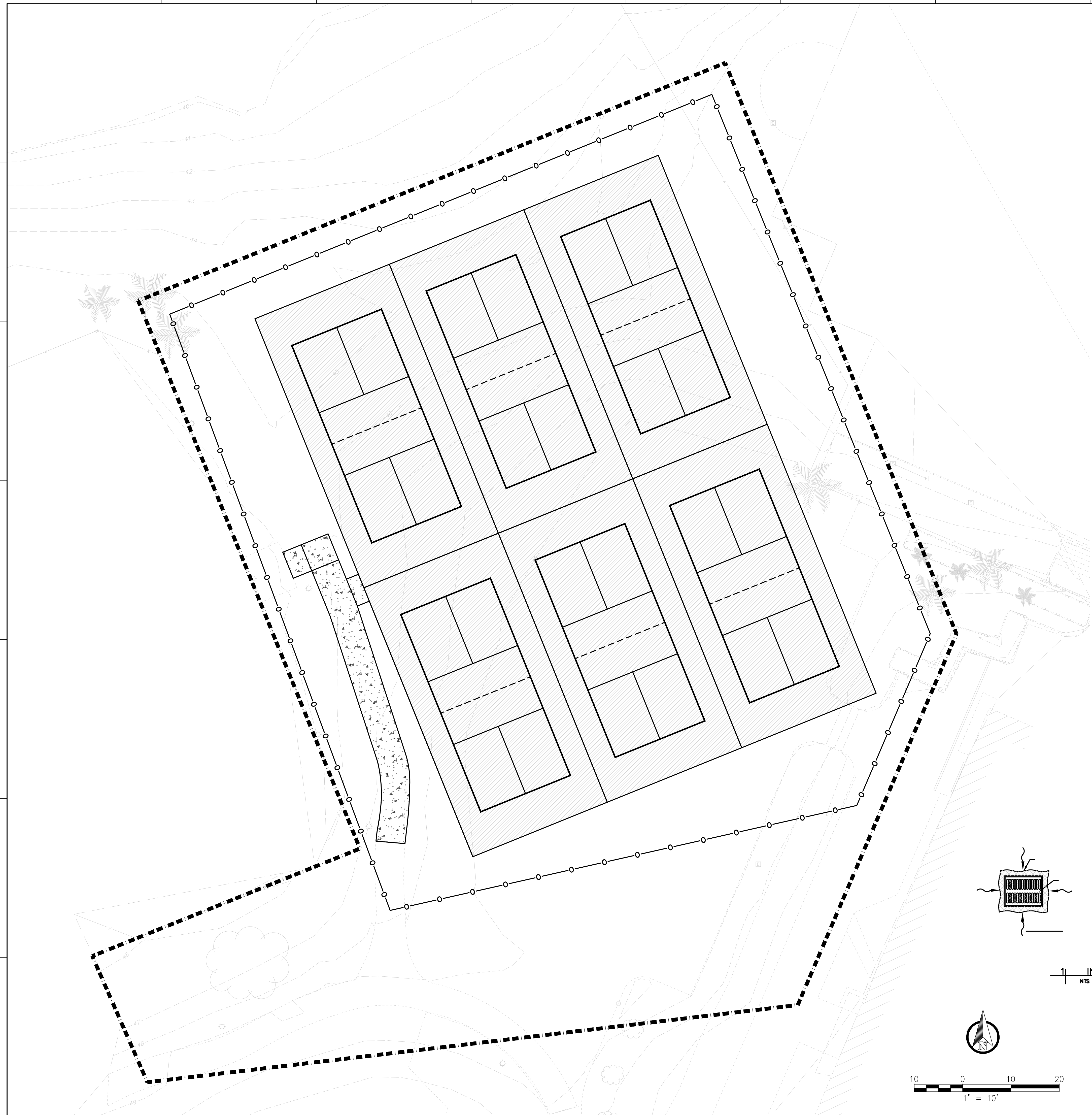
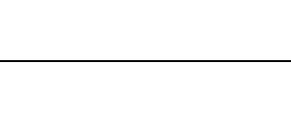

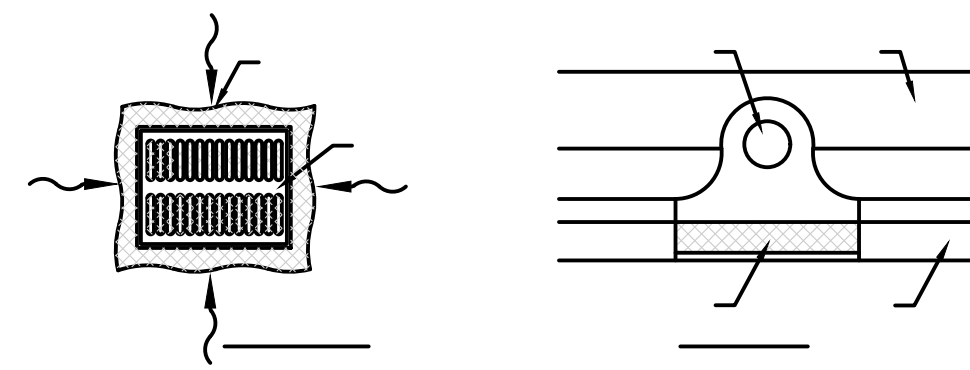
1 INLET PROTECTION  
NTS

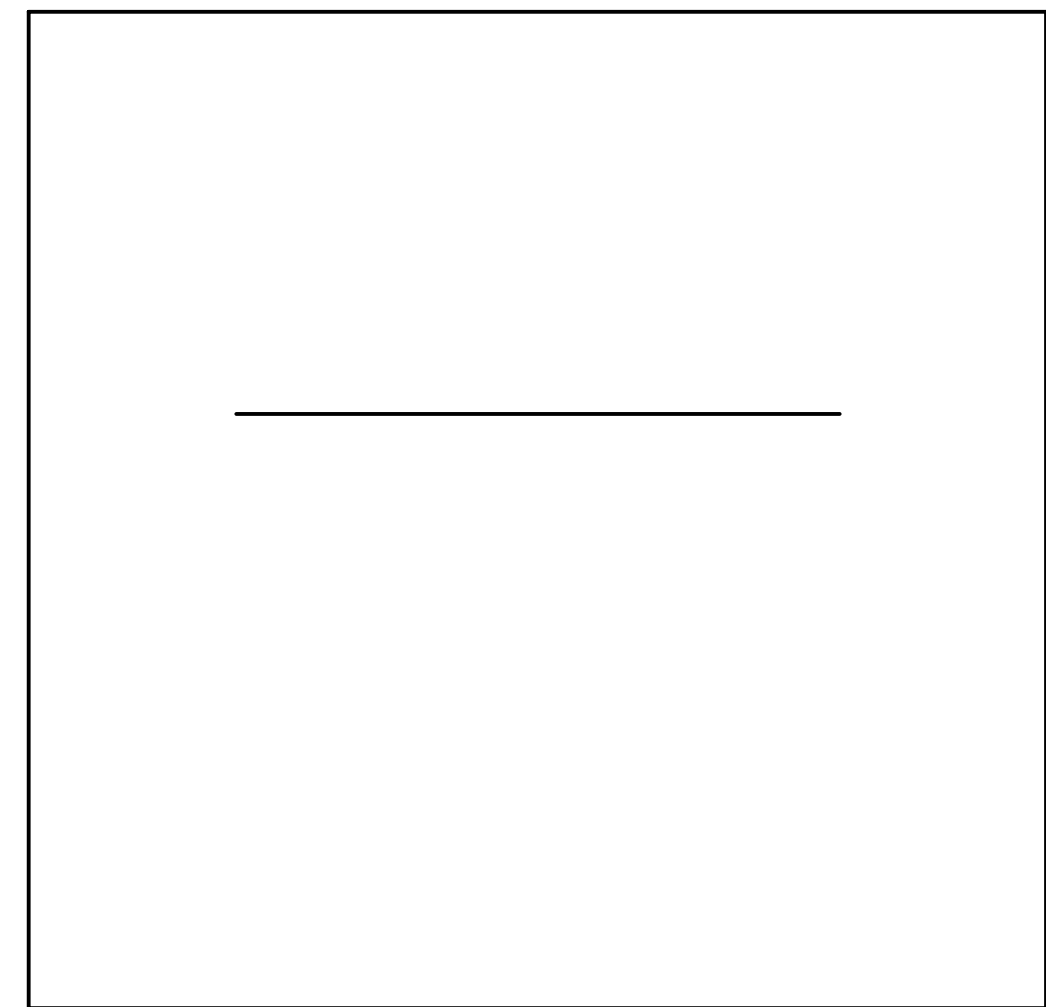
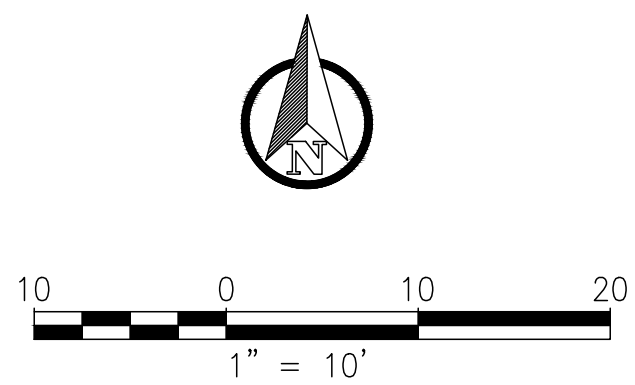

A  
B  
C  
D







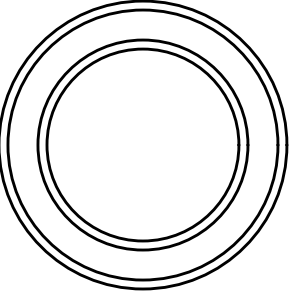

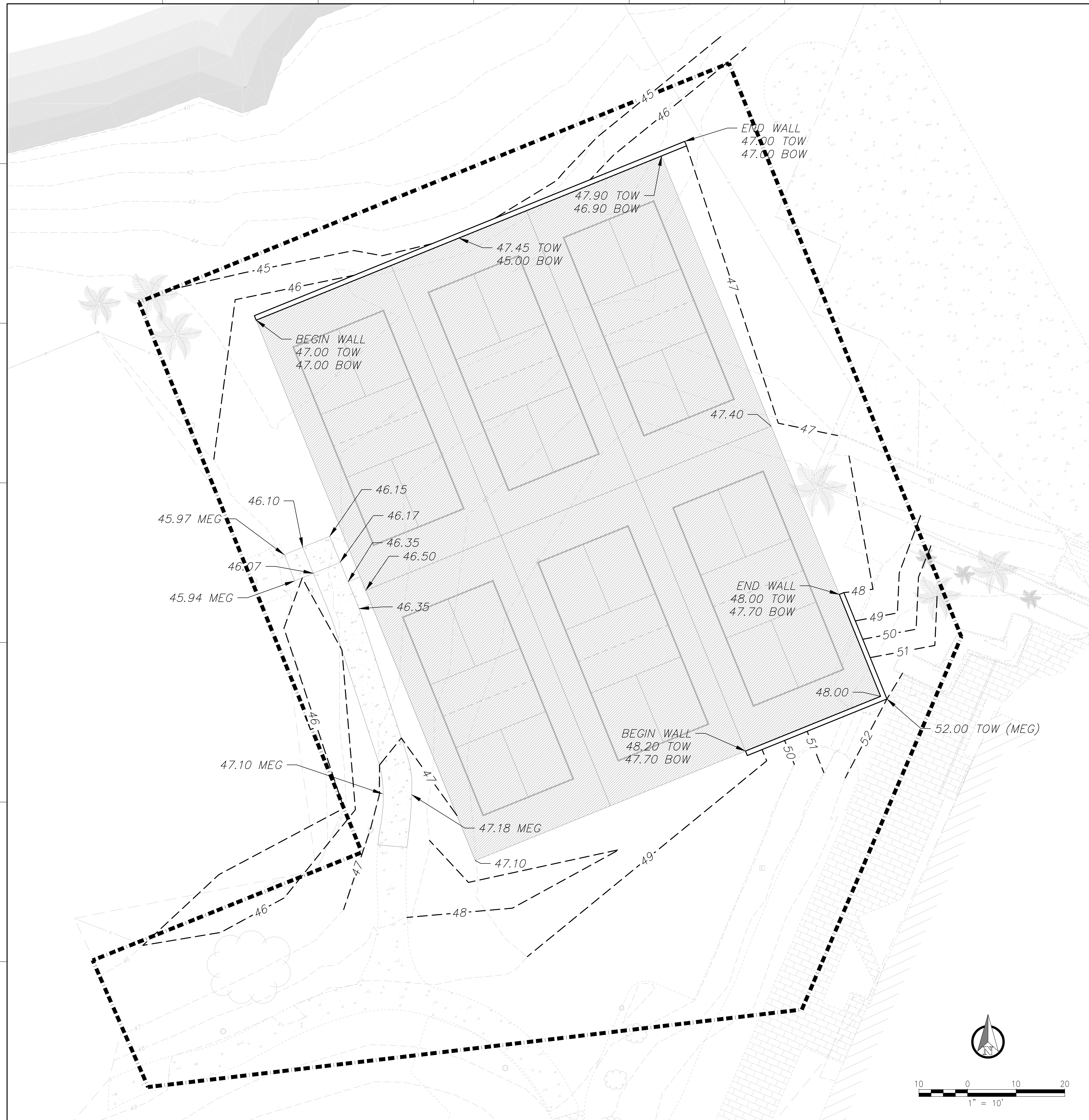

**NOTES:**

1. ALL SLOPES 5:1 AND GREATER SHALL BE STABILIZED WITH SOD, VEGETATION, OR OTHER MECHANICAL MEANS WITHIN 7-10 DAYS OF FINAL GRADING. REFER TO LANDSCAPE PLANS AND SPECS FOR APPROPRIATE SOIL STABILIZATION TECHNIQUE.
2. ADDITIONAL NOTES CAN BE FOUND ON THE GENERAL NOTES SHEET C0.01.



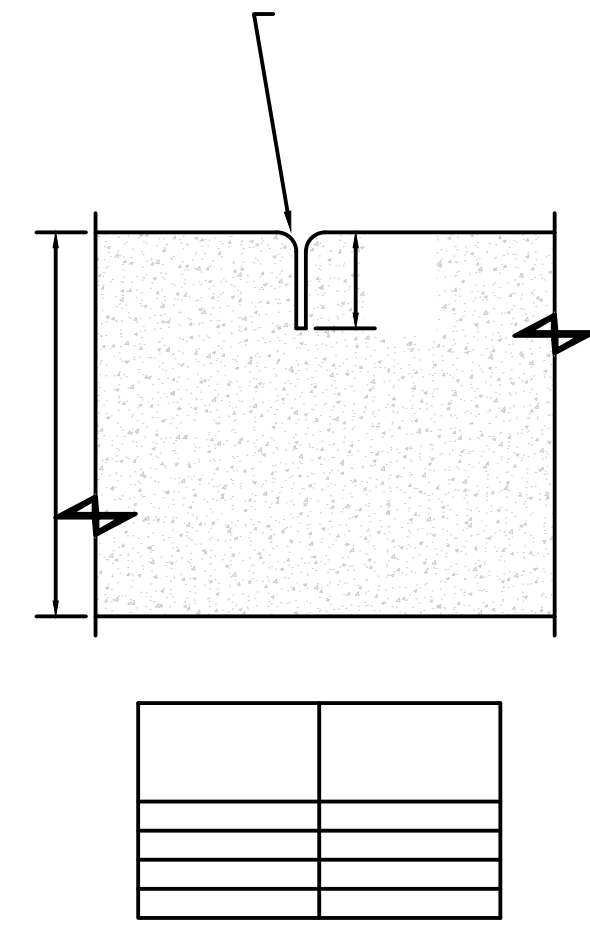
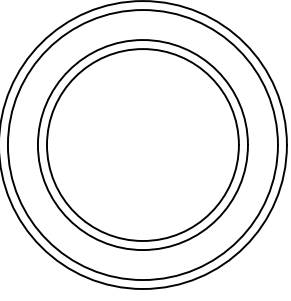



5 | CONTROL JOINT DETAIL  
NTS

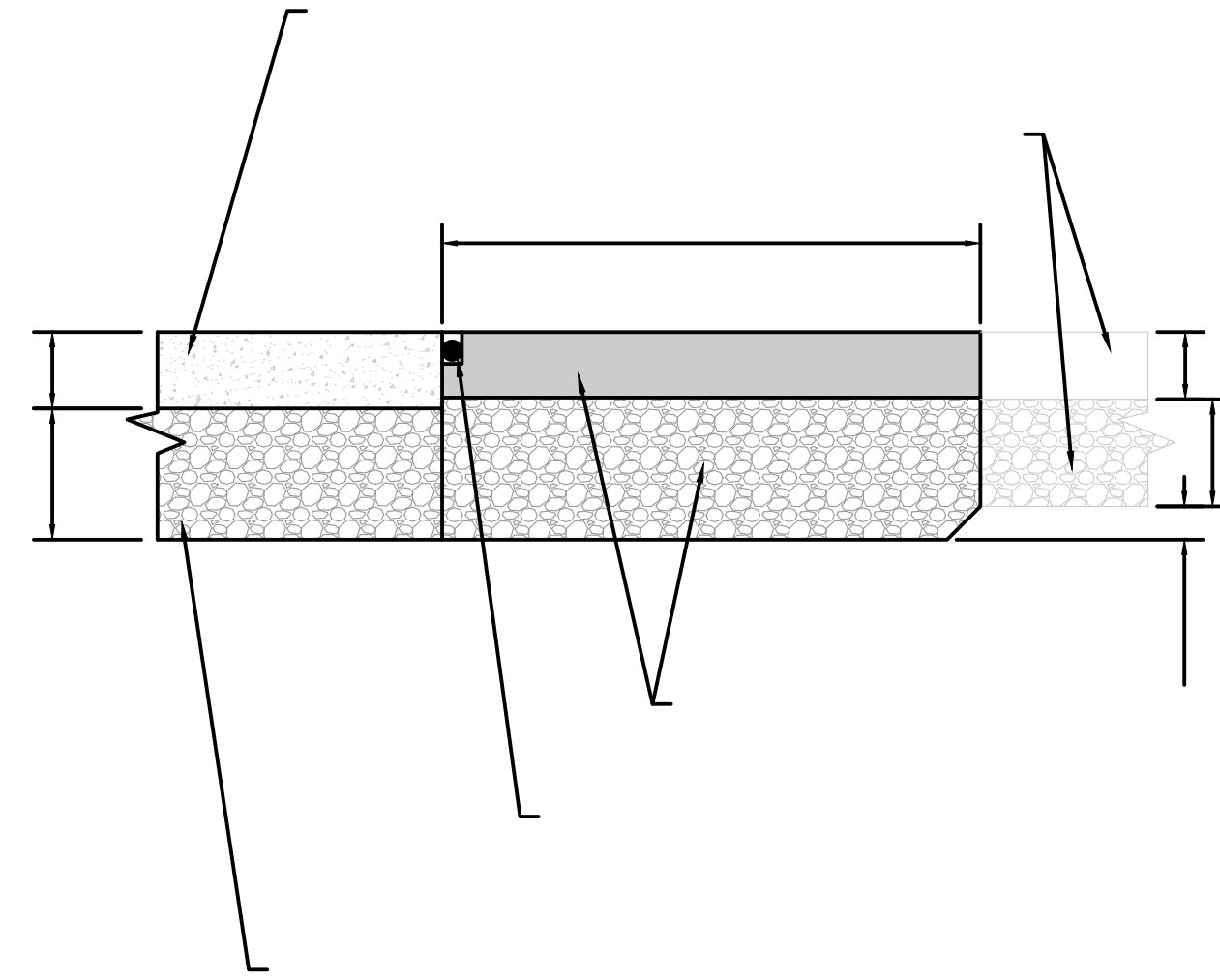

3 | ADJOINING CONCRETE TO EXISTING ASPHALT DETAIL  
NTS

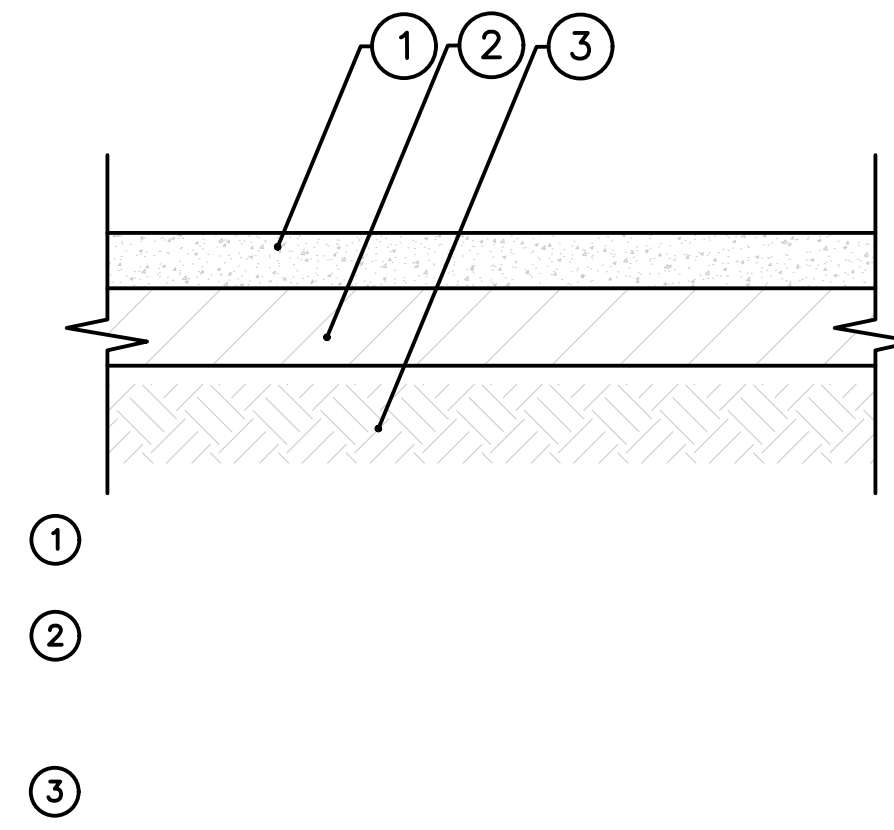

4 | NON-VEHICULAR USE CONCRETE PAVEMENT DETAIL  
NTS

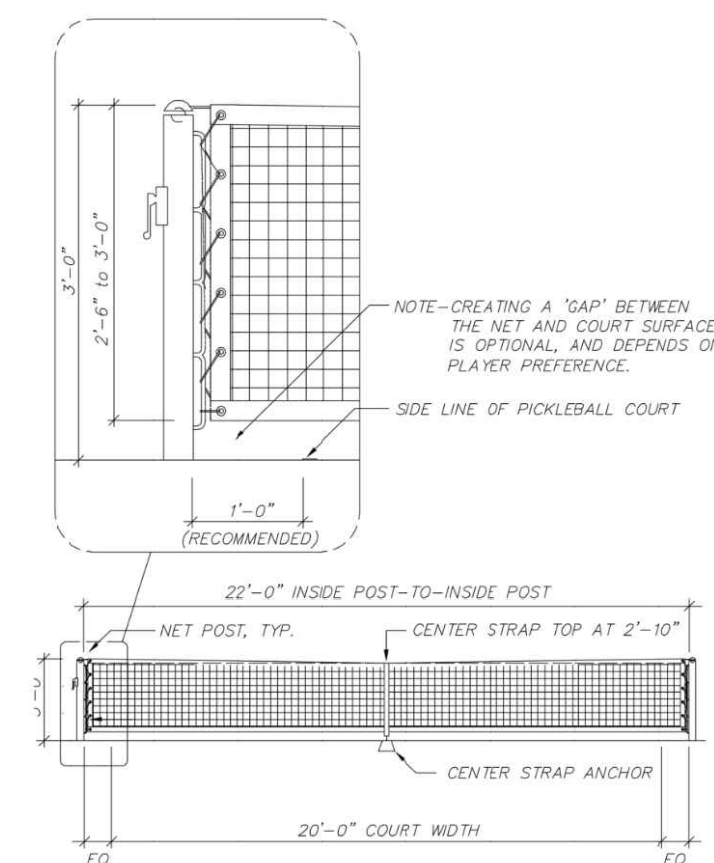

NOTE: PICKLEBALL COURTS TO BE CONSTRUCTED PER ARBAUSA PICKLEBALL CONSTRUCTION MANUAL.  
1 | PICKLEBALL NET ELEVATIONS  
NTS. PROVIDED BY NEY SPORTS CONSTRUCTION

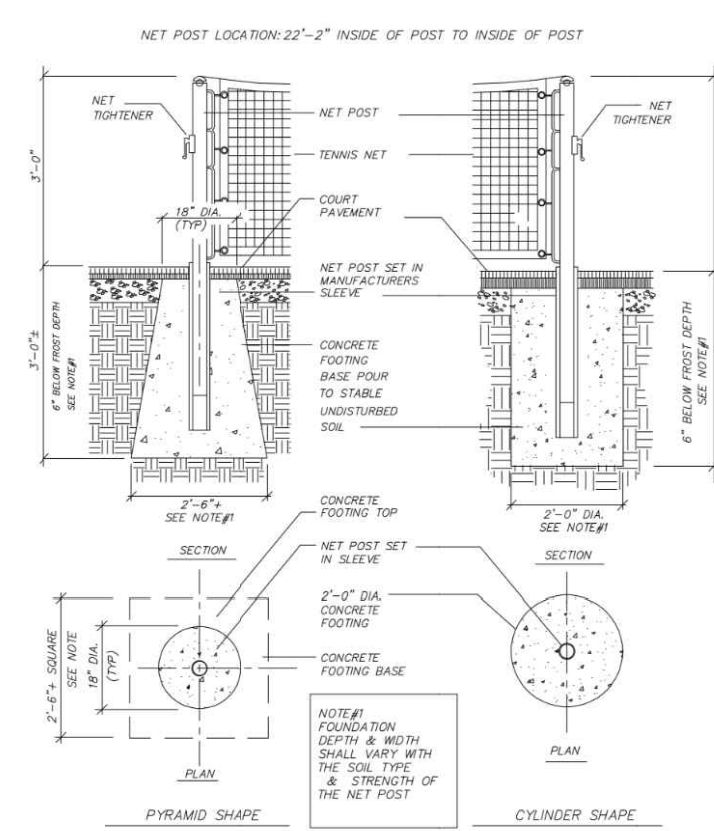

NOTE: PICKLEBALL COURTS TO BE CONSTRUCTED PER ARBAUSA PICKLEBALL CONSTRUCTION MANUAL.  
2 | NET POST FOOTINGS  
NTS. PROVIDED BY NEY SPORTS CONSTRUCTION

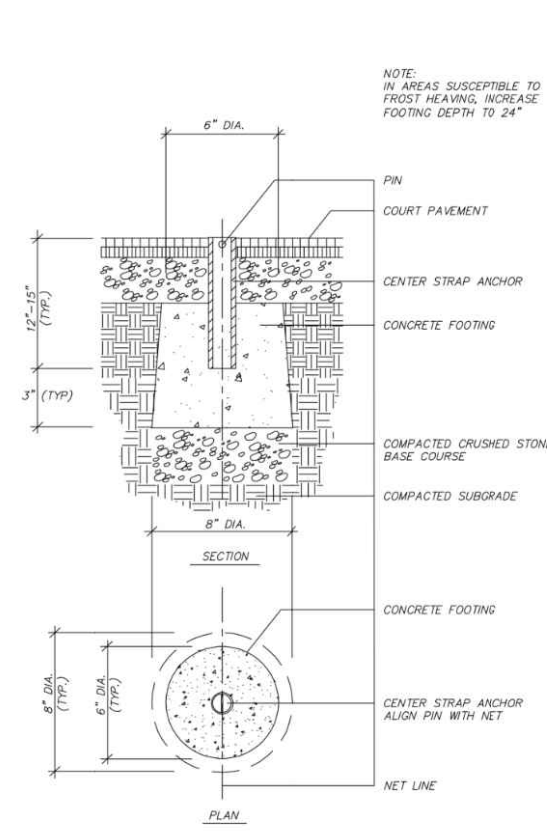

NOTE: PICKLEBALL COURTS TO BE CONSTRUCTED PER ARBAUSA PICKLEBALL CONSTRUCTION MANUAL.  
3 | PICKLEBALL NET CENTER STRAP ANCHOR  
NTS. PROVIDED BY NEY SPORTS CONSTRUCTION

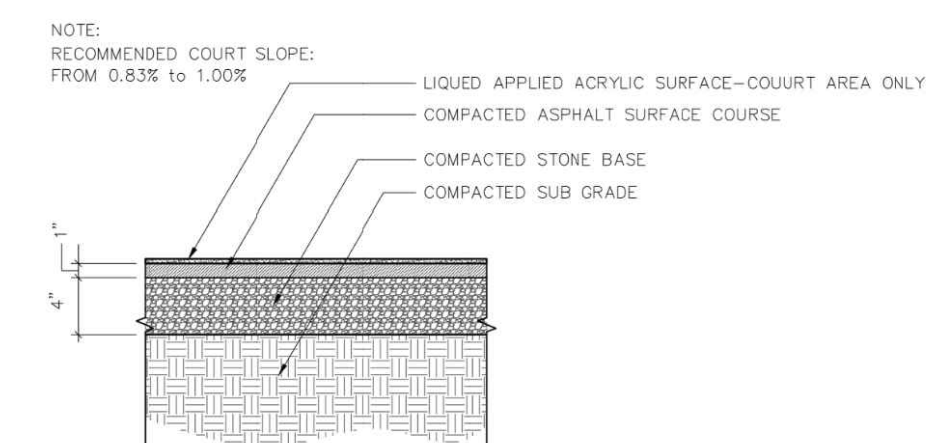

NOTE: RECOMMENDED COURT SLOPE: FROM 0.83% TO 1.00%.  
4 | ASPHALT COURT FOR NON-FREEZE/THAW CLIMATE  
NTS. PROVIDED BY NEY SPORTS CONSTRUCTION

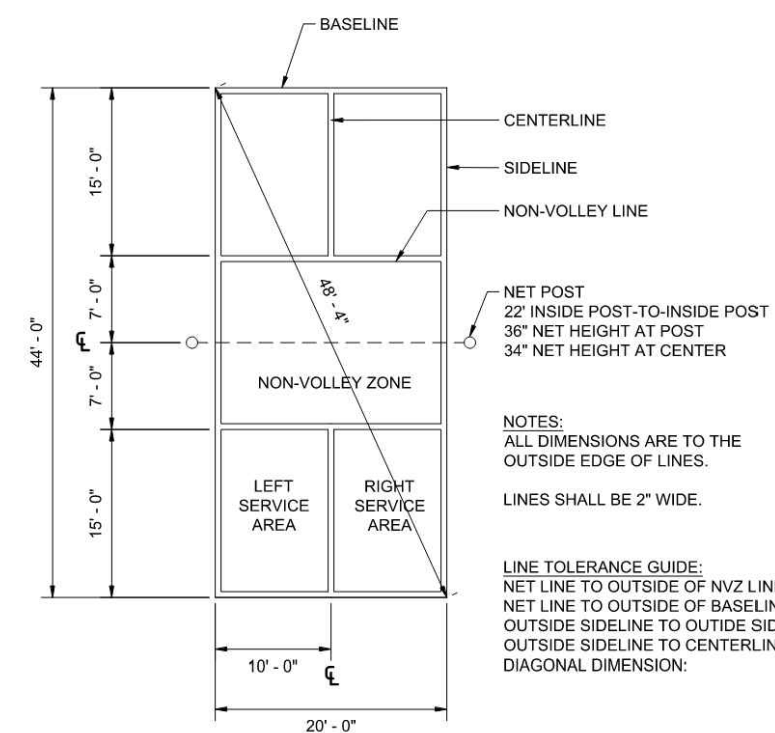

5 | COURT-PLAYING LINE LAYOUT  
NTS. PROVIDED BY NEY SPORTS CONSTRUCTION

NOTES:  
ALL DIMENSIONS ARE TO THE OUTSIDE EDGE OF LINES.  
LINES SHALL BE 2" WIDE.

LINE TOLERANCE GUIDE:  
NET LINE TO OUTSIDE OF NVZ LINE: 7'-0" ± 1/8"  
NET LINE TO OUTSIDE OF BASELINE: 22'-0" ± 1/4"  
OUTSIDE SIDELINE TO OUTSIDE SIDELINE: 20'-0" ± 1/4"  
OUTSIDE SIDELINE TO CENTERLINE: 10'-0" ± 1/8"  
DIAGONAL DIMENSION: 48'-4" ± 3/4"



# Property Record Card



**Parcel** 12-20-29-300-0140-0000

**Property Address** 150 TOURNAMENT DR LAKE MARY, FL 32746

## Parcel Location

## Site View



12202930001400000 05/12/2023

## Parcel Information

## Value Summary

<b>Parcel</b>	12-20-29-300-0140-0000
<b>Owner(s)</b>	CONCERT HEATHROW LLC
<b>Property Address</b>	150 TOURNAMENT DR LAKE MARY, FL 32746
<b>Mailing</b>	1200 BRIDGEWATER DR LAKE MARY, FL 32746-4342
<b>Subdivision Name</b>	
<b>Tax District</b>	01-COUNTY-TX DIST 1
<b>DOR Use Code</b>	34-RECREATIONAL FACILITY
<b>Exemptions</b>	None
<b>AG Classification</b>	No
<b>Facility Name</b>	HEATHROW RACQUET CLUB

	2024 Working Values	2023 Certified Values
<b>Valuation Method</b>	Cost/Market	Cost/Market
<b>Number of Buildings</b>	1	1
<b>Depreciated Building Value</b>	\$616,421	\$580,299
<b>Depreciated Other Features</b>	\$761,291	\$704,952
<b>Land Value (Market)</b>	\$884,401	\$884,401
<b>Land Value Agriculture</b>		
<b>Just/Market Value</b>	\$2,262,113	\$2,169,652
<b>Portability Adjustment</b>		
<b>Save Our Homes Adjustment</b>	\$0	\$0
<b>Non-Hx 10% Cap (AMD 1)</b>	\$0	\$60,842
<b>P&amp;G Adjustment</b>	\$0	\$0
<b>Assessed Value</b>	\$2,262,113	\$2,108,810

## 2023 Certified Tax Summary

**2023 Tax Amount w/o Non-Hx Cap** \$28,873.73    **2023 Tax Savings with Non-Hx Cap** \$482.48  
**2023 Tax Bill Amount** \$28,391.25

* Does NOT INCLUDE Non Ad Valorem Assessments

## Legal Description

SEC 12 TWP 20S RGE 29E  
 BEG 341.62 FT N OF SW COR SEC 12  
 RUN WLY ALONG NLY R/W LAKE MARY  
 BLVD 341.88 FT N 23 DEG 34 MIN 14  
 SEC W 596.54 FT N 520.90 FT E 700  
 FT S 49 DEG 39 MIN 03 SEC E 374.19  
 FT S 875 FT TO NLY R/W N 83 DEG 50  
 MIN 18 SEC W 199.92 FT S 06 DEG 09  
 MIN 42 SEC W 4 FT WLY ALONG NLY R/W  
 207.60 FT TO BEG (LESS FROM SE COR SEC RUN N 341.62 FT WLY ALONG CURVE 201.37 FT W 141.32 FT N 23 DEG 34 MIN 14 SEC W 166.51 FT TO  
 POB RUN N 23 DEG 34 MIN 14 SEC W 360.23 FT N 66 DEG 25 MIN 46 SEC E 185 FT S 23 DEG 34 MIN 14 SEC E 103.33 FT SLY ALONG CURVE 145.08



ROAD DISTRICT	\$2,262,113	\$0	\$2,262,113
FIRE	\$2,262,113	\$0	\$2,262,113
Schools	\$2,262,113	\$0	\$2,262,113

ACREAGE	17.67	\$71,500.00	\$884,384
ACREAGE	2.16	\$11.32	\$17

### Building Information

#	Description	Year Built Actual/Effective	Stories	Total SF	Ext Wall	Adj Value	Repl Value	Appendages	
1	MASONRY PILASTER .	1986	1	8321.00	CONCRETE BLOCK-STUCCO - MASONRY	\$616,421	\$1,058,233	<b>Description</b>	<b>Area</b>
								OPEN PORCH FINISHED	2910.00
								OPEN PORCH UNFINISHED	121.00
								CANOPY	1201.00



## Permits

Permit #	Description	Agency	Amount	CO Date	Permit Date
04733	REROOF	County	\$35,000		6/22/2012
11760	ELECTRICAL SERVICE FOR TENNIS LIGHTS.	County	\$10,000		12/2/2014
09022	FIRE ALARM SYSTEM INSTALLATION	County	\$18,400		12/5/2012
12296	MECHANICAL.	County	\$28,760		12/18/2014
05468	ELECTRIC	County	\$5,000		7/28/2015
06531	150 TOURNAMENT DR: PLUMBING - COMMERCIAL-recreational facility	County	\$10,258		5/18/2020
06400	150 TOURNAMENT DR: SIDING/AWNINGS/AL ROOF/CANOPY COMMERCIAL-Motorized Pergola	County	\$75,000		5/19/2020
15710	150 TOURNAMENT DR: STRUCTURES OTHER THAN BUILDINGS-WATER SLIDE	County	\$50,000		5/26/2022
20643	150 TOURNAMENT DR: STRUCTURES OTHER THAN BUILDINGS-Gas Pool Heater	County	\$92,979		11/22/2022

## Other Features

Description	Year Built	Units	Value	New Cost
SPA 3	07/01/1986	1	\$7,776	\$19,440
POOL COMMERCIAL	07/01/1986	3,727	\$130,415	\$217,359
SPA 3	07/01/1986	2	\$15,552	\$38,880
4' CHAIN LINK FENCE	07/01/1986	240	\$748	\$1,870
8' CHAIN LINK FENCE	07/01/1986	696	\$4,338	\$10,844
10' CHAIN LINK FENCE	07/01/1986	1,040	\$8,100	\$20,249
COMM: TENNIS COURT	07/01/1986	64,528	\$106,342	\$265,855
POLE LIGHT 2 ARM	07/01/1986	40	\$144,200	\$144,200
POLE LIGHT 2 ARM	07/01/1986	50	\$180,250	\$180,250
BRICK DRIVEWAY	07/01/1986	792	\$2,230	\$5,576
CANOPY AVG COMM	07/01/1986	640	\$3,223	\$8,058
BRICK WALL	07/01/1986	1,728	\$8,073	\$20,183
GAS HEATER	01/01/2022	2	\$2,975	\$3,306
COOL DECK PATIO	07/01/1986	17,550	\$30,958	\$77,396
COMMERCIAL CONCRETE DR 4 IN	07/01/1986	20,454	\$38,126	\$95,316
COMMERCIAL ASPHALT DR 2 IN	07/01/1986	51,664	\$50,631	\$126,577
IRON FENCE	07/01/1986	1,464	\$5,106	\$12,766
POLE LIGHT 1 ARM	07/01/1986	12	\$22,248	\$22,248



## Zoning

Zoning	Zoning Description	Future Land Use	Future Land Use Description
PD	Planned Development	PD	Planned Development

## Utility Information

Fire Station	Power	Phone(Analog)	Water Provider	Sewer Provider	Garbage Pickup	Recycle	Yard Waste	Hauler
36.00	DUKE	AT&T	SEMINOLE COUNTY UTILITIES	SEMINOLE COUNTY UTILITIES	NA	NA	NA	NA

## Political Representation

Commissioner	US Congress	State House	State Senate	Voting Precinct
Dist 5 - Andria Herr	Dist 7 - Cory Mills	Dist 36 - RACHEL PLAKON	Dist 10 - Jason Brodeur	11

## School Information

Elementary School District	Middle School District	High School District
Heathrow	Markham Woods	Seminole

Copyright 2024 © Seminole County Property Appraiser





**Seminole County Government  
Development Services Department  
Planning and Development Division  
Credit Card Payment Receipt**

If you have questions about your application or payment, please email us [eplandesk@seminolecountyfl.gov](mailto:eplandesk@seminolecountyfl.gov) or call us at: (407) 665-7371.

**Receipt Details**

**Date:** 5/20/2024 1:51:44 PM  
**Project:** 24-80000068  
**Credit Card Number:** 47*****5611  
**Authorization Number:** 084301  
**Transaction Number:** 20052403A-C6DB8884-B58A-4D6C-92EB-B2058A26D4C4  
**Total Fees Paid:** 52.50

**Fees Paid**

<b>Description</b>	<b>Amount</b>
CC CONVENIENCE FEE -- PZ	2.50
PRE APPLICATION	50.00
Total Amount	52.50